



# 2170 VEHICULAR DC SLIDE GATE OPERATOR

## THE NEXT GENERATION OF ACCESS CONTROL

### Smart, brushless DC slide gate automation with battery backup

- 115 / 230 VAC selectable input or 24 VDC
- Brushless DC motor available in 500W (½ HP) or 750W (1 HP) configurations
- Removable cover allows fast, unobstructed access
- Heavy-duty steel frame built for continuous-duty operation
- Moves gates up to 40 ft or 3,500 lbs
- Integrated battery backup with two (2) 7.5 Ah batteries
- 5-year limited warranty
- Five (5) programmable relays
- Six (6) programmable UL inputs
- Built-in Diagnostics

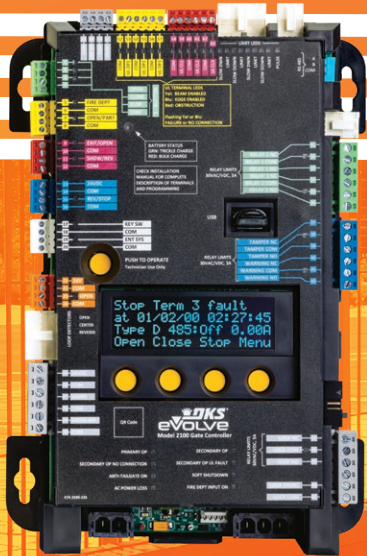

### eVolve™ Smart Controller

Built-in smart controls with Digital Onboard Operator Controls and Programming Access Controller via RS485. USB configuration backup, event logging, and diagnostics.

### Residential • Commercial • Industrial



### Easy Onboard Programming

Intuitive onboard LCD interface allows fast setup, adjustment, and diagnostics directly at the operator—no external devices required.



### Powerful Brushless DC Motors

Up to 3,500 lb slide gate capacity for demanding residential and commercial applications.



### Built from the Ground Up

Heavy-duty steel construction with a durable semi-gloss black powder coat engineered for continuous-duty residential and commercial applications.

ACCESS CONTROL SOLUTIONS

# DKS<sup>®</sup> eVolve<sup>™</sup> 2170 VEHICULAR DC SLIDE GATE OPERATOR

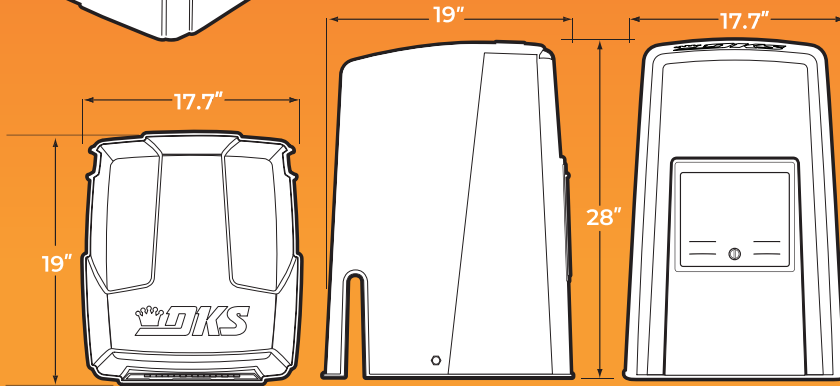

2170-380 / 382

2170-381 / 383

|   | 2170-380 / 382   | 2170-381 / 383   |
|---|--|--|
| <b>CLASS OF OPERATION</b>                               | I, II, III, IV   | I, II, III, IV   |
| <b>MAX GATE LENGTH</b>                                  | 40 ft<br>(12.192 m)  | 40 ft<br>(12.192m)   |
| <b>MAX GATE WEIGHT</b>                                  | 2,300 lb<br>(1043 kg)  | 3,500 lb<br>(1587 kg)  |
| <b>MOTOR</b>  | Motor Brushless 36 VDC <sup>1</sup><br>500W (½ HP)                           | Motor Brushless 36 VDC <sup>1</sup><br>750W (1 HP)                           |
| <b>INPUT</b>  | 115 / 230 - 1 <sup>Ø</sup> VAC<br>5 A / 3 A                                  | 115 / 230 - 1 <sup>Ø</sup> VAC<br>7A / 4A                                    |
| <b>AC POWER CYCLES PER HOUR</b>                         | Continuous   | Continuous   |
| <b>BATTERY BACK-UP<sup>2</sup></b><br>(QTY. 2 REQUIRED) | 60 cycles with<br>7.5 Ah batteries<br><br>150 cycles with<br>18 Ah batteries | 40 cycles with<br>7.5 Ah batteries<br><br>100 cycles with<br>18 Ah batteries |

Note 1: 36 VDC motor is operated at 24 VDC.

Note 2: Approximate cycles. The number of cycles using only battery back-up will vary depending on the weight of the gate, the length of the gate, the operating condition of the gate, temperature and the charge state of the batteries.

## TECHNICAL FEATURES

**Class of Operation:** I, II, III, IV

**Maximum Gate Weight:**

- 2170-380 / 382: 2,300 lb

- 2170-381 / 383: 3,500 lb

**Maximum Gate Length:**

- 2170-380 / 382: 40 ft

- 2170-381 / 383: 40 ft

**Pulling Medium:** #40 Nickel Chain

**Adjustable Speed:** 12 in/Sec (max)

**Gearbox Reduction:** 30:1

**Power Loss Operation:** Push Button, Constant Pressure

**Manual Release:** Internal/Manual

**Motor (Brushless 36 VDC<sup>1</sup>):**

- 2170-380 / 382: 500W (½ HP)

- 2170-381 / 383: 750W (1 HP)

**Input Power VAC:** 115 / 230 - 1<sup>Ø</sup>

**Amps (115 / 230 VAC):**

- 2170-380 / 382: 5A / 3A

- 2170-381 / 383: 7A / 4A

**Accessory Device Power:** 24 VDC, 3A

**Battery Backup:** Two (2) 7.5 Ah batteries

## SMART CONTROLS (EVOLVE<sup>™</sup>)

- Onboard LCD operator programming USB configuration backup and restore
- Built-in diagnostics and event logging
- Supports plug-in accessory hub modules
- Compatible with DKS access control systems

## MISCELLANEOUS

**Environmental:**

-10°F to 158°F (-23°C to 70°C)

With optional heater kit: -40°F to 158°F (-40°C to 70°C)

**Heater Kit:**

Thermostatically controlled heater kit required for operation below freezing temperatures to prevent battery damage.

Heater kit is for AC-powered operators only.

**Shipping Weight:**

Approximately 175-225 lb (79-102 kg), depending on model and options selected.

**Safety Requirements:**

Operator requires monitored Type B1 and/or Type B2 entrapment protection devices.



## DoorKing<sup>®</sup>, Inc.

Access Control Solutions since 1948



120 S. Glasgow Avenue,  
Inglewood, California 90301 U.S.A.  
Tel: 310-645-0023 FAX: 310-641-1586  
www.doorking.com

© 2026 All Rights Reserved.  
Product specifications may  
change without notice. Rev. 5/26



**MEMBER:**



**DISTRIBUTED BY:**