

Installation Manual

1620 Lane Barrier

Surface Mount Vehicular Lane Barrier System

Use this manual for circuit board 1601-010 Revision AK or higher.

1620-065-V-6-26

The 1620 lane barrier is **NOT** a stand-alone product.
It **MUST** be used with a 1603-580 Barrier Gate Operator (sold separately).

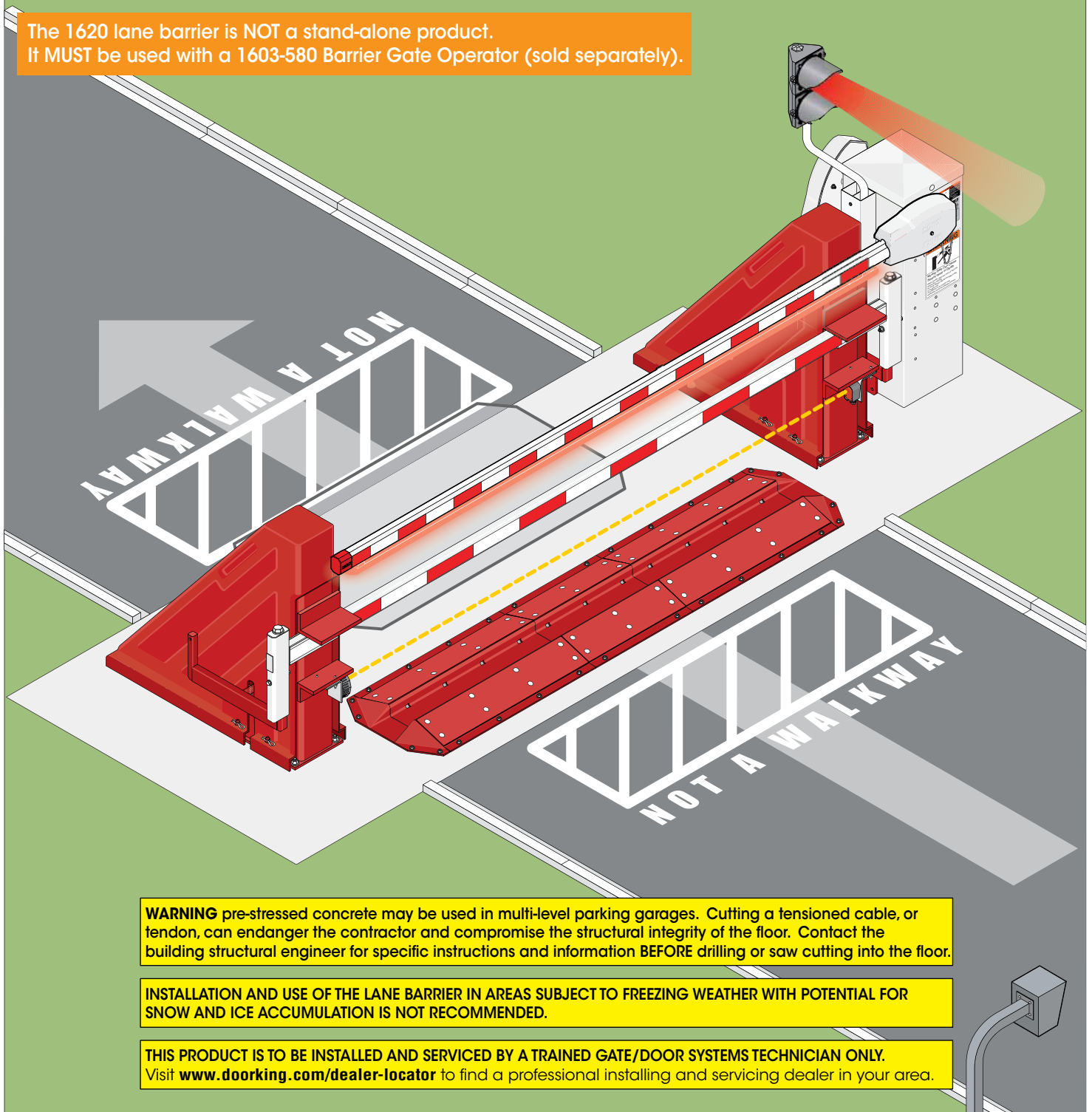

WARNING pre-stressed concrete may be used in multi-level parking garages. Cutting a tensioned cable, or tendon, can endanger the contractor and compromise the structural integrity of the floor. Contact the building structural engineer for specific instructions and information **BEFORE** drilling or saw cutting into the floor.

INSTALLATION AND USE OF THE LANE BARRIER IN AREAS SUBJECT TO FREEZING WEATHER WITH POTENTIAL FOR SNOW AND ICE ACCUMULATION IS NOT RECOMMENDED.

THIS PRODUCT IS TO BE INSTALLED AND SERVICED BY A TRAINED GATE/DOOR SYSTEMS TECHNICIAN ONLY.
Visit www.doorking.com/dealer-locator to find a professional installing and servicing dealer in your area.

Copyright 2026 DoorKing®, Inc. All rights reserved.

The 1620 is not crash rated. It is intended to provide a more formidable barrier in conjunction with a standard barrier arm operator system. The 1620 is ideally used to control passenger vehicles and lightduty trucks.



TABLE OF CONTENTS

LANE BARRIER OPERATOR and ARM OPTIONS

2

LAND BARRIER MODEL CONFIGURATIONS

3

SECTION 1 - IMPORTANT SAFETY INFORMATION

1.1 Important Safety Instructions (English, French)	4
1.2 Instructions regarding intended installation: (English, French)	4-6
1.3 DoorKing 8080-057 Photocell Type B-1 - INCLUDED	6
1.4 IMPORTANT Safety Information for Lane Barrier System	7-8
1.5 Safety and Traffic Management for Lane Barrier System	9
1.6 Lane Barrier ONE-WAY Operation	10

SECTION 2 - CONCRETE SETUP OPTIONS

EXISTING Concrete	11
NEW Concrete Pad	11
Concrete Requirements and Dimensions	11
2.1 Underground Conduit	12
Suggested 8080-057 Photocell Position	12-13
Suggested Underground Conduit Layout for a DOWN Loop (Optional)	13
2.2 Critical Measurements	14

SECTION 3 - MOUNTING OPERATOR AND LAND BARRIER STEPS

1 Permanently Mount Operator	14
2 Permanently Mount Support Post Next to Operator	14
3 Bolt Lane Arm on Support Posts	15
4 Permanently Mount other Support Post	15
5 Permanently Mount Arm Channels	16
6 Connect Operator to Lane Barrier	17
7 Install Covers	18
8 Warning Signage (Optional)	18
9 Install Arm and OPTIONAL Traffic Light	18
Regular Maintenance of Lane Barrier System	18

SECTION 4 - Photocell

19

SECTION 5 - IN-GROUND LOOP OPTIONS

20

SW2 DIP-Switch 3 - Override DOWN Loop Commands Layouts	21
--	----

SECTION 6 - MANUAL RELEASE OPTIONS

22

LANE BARRIER OPERATOR and ARM OPTIONS

1603-580 Lane Barrier Operator

Class of Operation - UL 325 Class II, III, IV – ETL Listed

Type of Gate - Use with 1620 Series Lane Barriers Only

Arm Types - **Octagon Arm ONLY** – Straight or Folding
(NO Break-Away)

Gate Cycles - Low Cycle

Pedestrian Protection -

Inherent entrapment sensing system - **Type A**

Provision for connection of a non-contact sensor - **Type B1**

and/or contact sensor - **Type B2**

**DKS Reflective
PhotoCell
(Included)**
P/N 8080-057

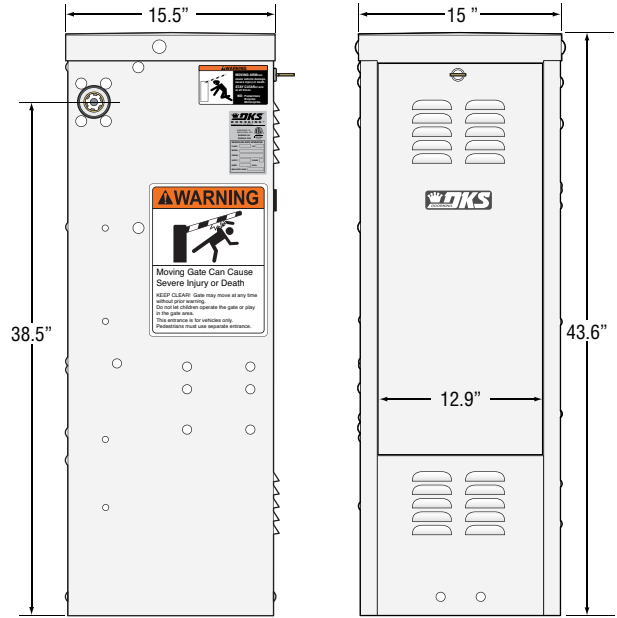
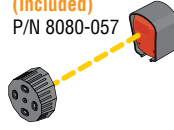

Model #	Convenience Open	Manual Release	Horsepower - Volts	Amp	Max Arm Length	Speed 90°
1603-580	No	Yes	1/2 HP - 115 VAC	5.7	14 Ft	2.5 Sec

Note: 208/230/460/575 VAC input voltage can be connected to the operator by installing an **“Optional”** High Voltage Kit (P/N 2600-266).

Type of wiring to be used on ALL external devices:

A) Type CL2, CL2P, CL2R, or CL2X.

B) Other cable with **equivalent** or **better** electrical, mechanical, and flammability ratings.

Drawings not to scale

Lane Barrier Operator Arm Options

14 Ft OCTAGON Arm

- Choose {
- 14 Ft 1-Piece Octagon Arm Only P/N 1601-555
 - 14 Ft 2-Piece Octagon Arm Only P/N 1601-567
- Octagon Arm Hardware Kit (Required) P/N 1601-242
Rubber Bumper (Optional) P/N 8080-089

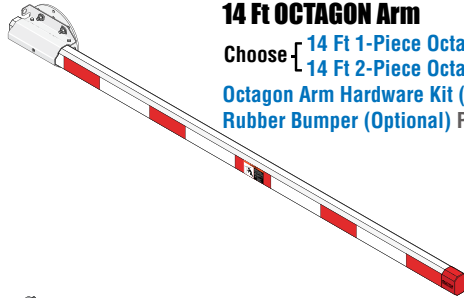

14 Ft Octagon Reverse Edge Arm

- Choose {
- 14 Ft 1-Piece Octagon Arm Only P/N 1601-555
 - 14 Ft 2-Piece Octagon Arm Only P/N 1601-567
- Octagon Arm Hardware Kit (Required) P/N 8080-235
Reverse Edge (Required) different lengths available
- Reverse Edge 5 Ft P/N 8080-605
 - Reverse Edge 6 Ft P/N 8080-606
 - Reverse Edge 9 Ft P/N 8080-609
 - Reverse Edge 12 Ft P/N 8080-612

Shortening Arm Note:

A 14 ft OCTAGON arm with an **EDGE** can **ONLY** be shortened to **SPECIFIC** lengths.

A shorter **Reverse** or **Reverse/LED Edge** will be needed. See instruction sheet that comes with the **STANDARD Arm Bracket** installation for more information **1601-268.pdf**.

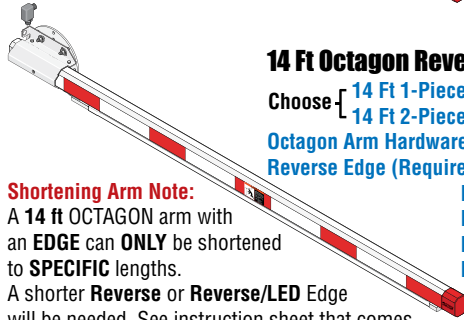

14 Ft Octagon Reverse/LED Edge Arm

- Choose {
- 14 Ft 1-Piece Octagon Arm Only P/N 1601-555
 - 14 Ft 2-Piece Octagon Arm Only P/N 1601-567
- Octagon Arm Hardware Kit (Required) P/N 8080-235
Reverse/LED Edge (Required) different lengths available
- Reverse/LED Edge 5 Ft P/N 8080-905
 - Reverse/LED Edge 6 Ft P/N 8080-906
 - Reverse/LED Edge 9 Ft P/N 8080-909
 - Reverse/LED Edge 12 Ft P/N 8080-912

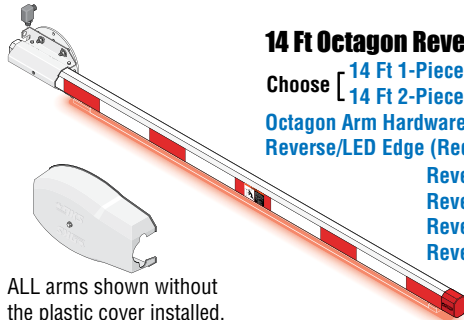

ALL arms shown without the plastic cover installed.

OCTAGON Folding Arm

- Two 6Ft Folding Octagon Arms Only
P/N 1601-812
Octagon Arm Hardware Kit (Required)
P/N 1601-242
Two Reverse/LED Edges Kit (Optional)
P/N 8080-922
Rubber Bumper (Optional)
P/N 8080-089

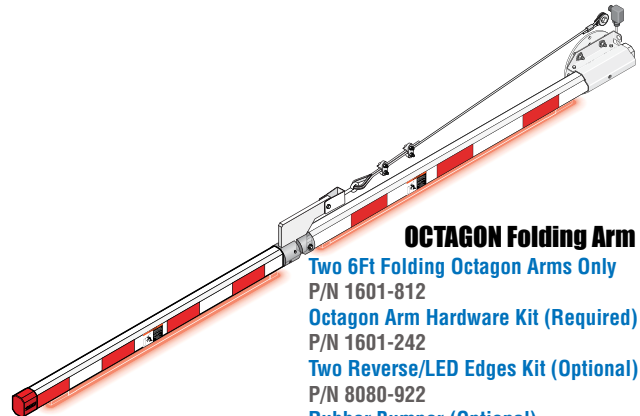

Contact Sensor Note: A **reverse edge** is **NOT** to be used as a replacement, or in lieu of, in-ground loops or non-contact sensor (photozell) that protect vehicles passing underneath the barrier arm. A **moving** vehicle coming in contact with a downward moving barrier arm **WILL** result in **damage to the vehicle** and the barrier arm/reversing edge if **NOT** using in-ground loops or non-contact sensor (Photozell).

LANE BARRIER MODEL CONFIGURATIONS

Prior to beginning the installation of the lane barrier, we suggest that you become familiar with the instructions, illustrations, and wiring guide-lines in this manual. This will help insure that your installation is performed in an efficient and professional manner.

Barrier operator 1603-580 can be installed on EITHER side of lane barrier

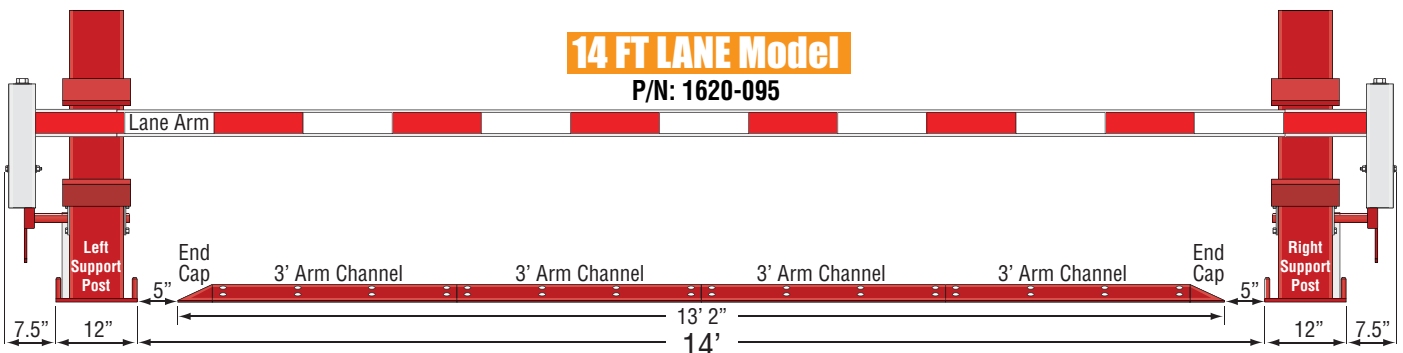
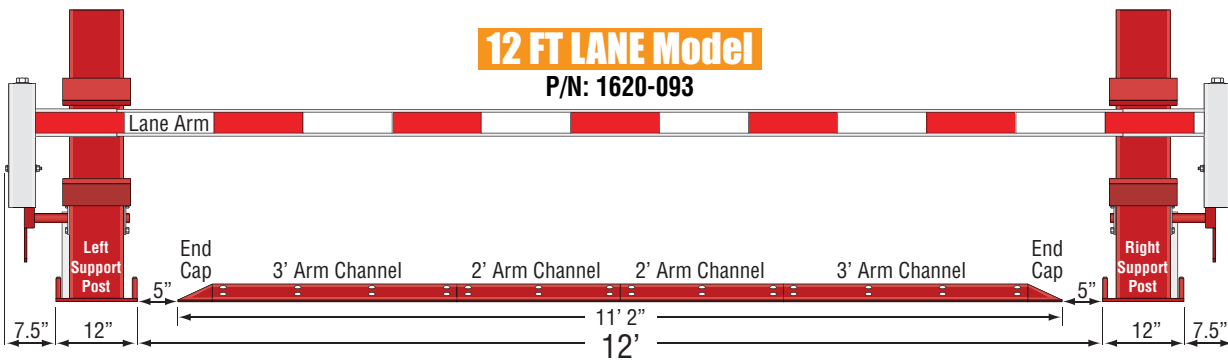
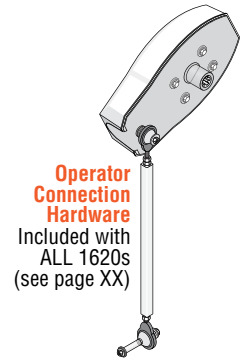
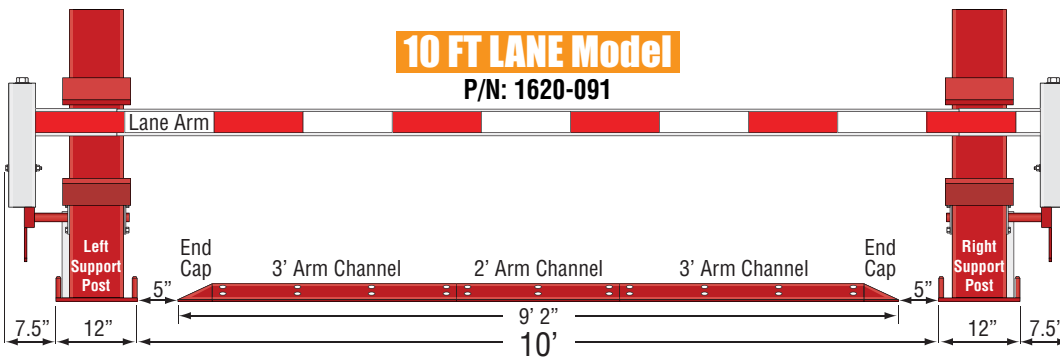
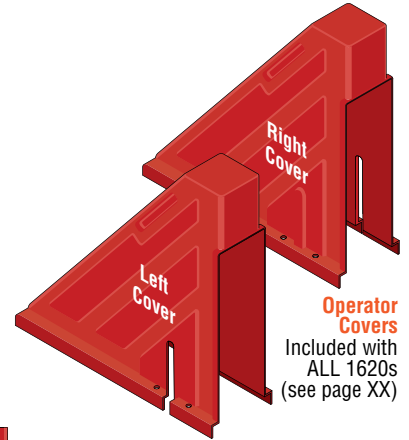
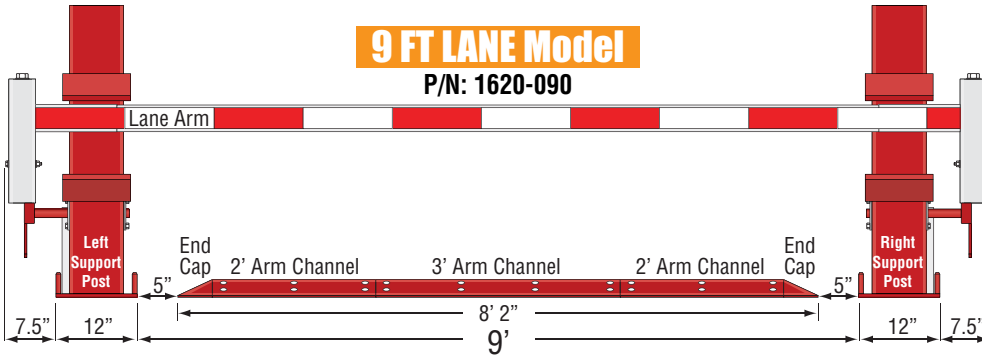

SECTION 1 - IMPORTANT SAFETY INFORMATION

1.1 Important Safety Instructions

English	French
<p>IMPORTANT SAFETY INSTRUCTIONS WARNING – To reduce the risk of severe injury or death:</p> <ol style="list-style-type: none"> 1. READ AND FOLLOW ALL INSTRUCTIONS. 2. Never let children operate or play with gate controls. Keep the remote control away from children. 3. Always keep people and objects away from the gate. NO ONE SHOULD CROSS THE PATH OF THE MOVING GATE. 4. Test the gate operator monthly. The gate MUST reverse on contact with a rigid object or stop when an object activates the non-contact sensors. After adjusting the force or the limit of travel, retest the gate operator. Failure to adjust and retest the gate operator properly can increase the risk of injury or death. 5. Use the manual release only when the gate is not moving. 6. KEEP GATES PROPERLY MAINTAINED. Read the user's manual. Have a qualified service person make repairs to gate hardware. 7. The entrance is for vehicles only. Pedestrians must use separate entrance. 8. SAVE THESE INSTRUCTIONS. 	<p>AVERTISSEMENT DE CONSIGNES DE SÉCURITÉ IMPORTANTES – Pour réduire le risques de blessures graves ou mortelles :</p> <ol style="list-style-type: none"> 1. LIRE ET SUIVRE TOUTES LES INSTRUCTIONS. 2. Ne jamais laisser les enfants faire fonctionner la porte ou jouer avec les commandes de la barrière. Garder la télécommande hors de la portée des enfants. 3. Toujours garder les personnes et les objets loin de la barrière. PERSONNE NE DEVRAIT FRANCHIR LA BARRIÈRE EN MOUVEMENT. 4. Vérifier l'ouvre-barrière une fois par mois. La barrière DOIT inverser son mouvement au contact d'un objet rigide, lorsque celui-ci active les capteurs sans contact. Après avoir réglé la force ou la limite du déplacement, vérifier de nouveau l'ouvre-barrière. Si l'ouvre-barrière est mal réglé ou n'est pas vérifié de manière appropriée, le risque de ou de blessures graves ou mortelles est accru. 5. Utiliser le dispositif de dégagement manuel uniquement si la barrière est immobilisée. 6. ASSURER L'ENTRETIEN ADÉQUAT DE LA BARRIÈRE. Lire le guide d'utilisation. Demander à un professionnel qualifié de réparer la quincaillerie de la barrière . 7. L'entrée est réservée aux véhicules . Les piétons doivent avoir une entrée distincte. 8. CONSERVER CES INSTRUCTIONS.

1.2 Instructions regarding intended installation:

English	French
<p>a) Install the gate operator only when:</p> <ol style="list-style-type: none"> 1) The operator is appropriate for the construction of the gate and the usage Class of the gate, 2) All openings of a horizontal slide gate are guarded or screened from the bottom of the gate to a minimum of 1.83 m (6 ft) above the ground to prevent a 57.2 mm (2-1/4 inch) diameter sphere from passing through the openings anywhere in the gate, and in that portion of the adjacent fence that the gate covers in the open position, 3) All areas of the moving vertical pivot gate panel from the bottom of the gate to the top of the gate or a minimum of 1.83 m (72 in) above grade, whichever is less, that pass by a fixed stationary object, and in the area of the adjacent fence that the gate covers during the travel of the gate, shall be designed, guarded or screened to prevent a 57 mm (2-1/4 in) diameter sphere from passing through such areas. 4) All exposed pinch points are eliminated or guarded, and 5) Guarding is supplied for exposed rollers. 6) The operator instructions shall list the maximum number of open and close entrapment protection devices capable of being connected to the operator. 	<p>a) Installer l'ouvre-barrière uniquement si :</p> <ol style="list-style-type: none"> 1) L'ouvre-barrière convient à la construction et la classe d'utilisation de la barrière. 2) Toutes les ouvertures de la barrière coulissante horizontale sont protégées ou grillagées du bas de la barrière jusqu'à au moins 1,83 m (6 pi) du sol si bien qu'une sphère de 57,2 mm (2 1/4 po) de diamètre ne peut passer par aucune ouverture dans la barrière ou dans la portion de la clôture adjacente que la barrière couvre en position ouverte. 3) Toutes les zones du panneau d'une barrière à pivot verticale du bas jusqu'au haut de la barrière ou jusqu'à au moins 1,83 m (72 po) au-dessus du sol (la hauteur la plus basse prévalant) qui passe par un objet immobile et dans la portion de la clôture adjacente que la barrière couvre pendant sa course sont conçues, protégées ou grillagées si bien qu'une sphère de 57 mm (2 1/4 po) de diamètre ne peut passer par de telles zones. 4) Tous les points de pincement sont éliminés ou protégés . 5) Des protections sont fournies pour les galets exposés. 6) Les instructions de l'ouvre-barrière doivent indiquer le nombre maximal de dispositifs de protection contre le coincement à l'ouverture ou à la fermeture.

1.2 Instructions regarding installation cont:

English	French
<p>b) The operator is intended for installation only on gates used for vehicles. Pedestrians must be supplied with a separate access opening. The pedestrian access opening shall be designed to promote pedestrian usage. Locate the gate such that persons will not come in contact with the vehicular gate during the entire path of travel of the vehicular gate.</p> <p>c) The gate must be installed in a location so that enough clearance is supplied between the gate and adjacent structures when opening and closing to reduce the risk of entrapment. Swinging gates shall not open into public access areas.</p> <p>d) The gate must be properly installed and work freely in both directions prior to the installation of the gate operator. Do not over-tighten the operator clutch or pressure relief valve to compensate for an improperly installed, improperly functioning, or damaged gate.</p> <p>e) For a gate operator utilizing Type D entrapment protection:</p> <ol style="list-style-type: none"> 1) The gate operator controls must be placed so that the user has full view of the gate area when the gate is moving, 2) The placard shall be placed adjacent to the controls, 3) An automatic closing device (such as a timer, loop sensor, or similar device) shall not be employed, and 4) No other activation device shall be connected. <p>f) Permanently mounted controls intended for user activation must be located at least 1.83 m (6 ft) away from any moving part of the gate and where the user is prevented from reaching over, under, around or through the gate to operate the controls.</p> <p>Exception: Emergency access controls only accessible by authorized personnel (e.g. fire, police, EMS) may be placed at any location in the line-of-sight of the gate.</p> <p>g) The Stop and/or Reset button must be located in the line-of-sight of the gate. Activation of the reset control shall not cause the operator to start.</p> <p>A minimum of two (2) WARNING SIGNS shall be installed, in the area of the gate. Each placard is to be visible by persons located on the side of the gate on which the placard is installed.</p> <p>i) For a gate operator utilizing Type B1, non-contact entrapment protection:</p> <ol style="list-style-type: none"> 1) See instructions on the placement of non-contact sensors for each Type of application, 2) Care shall be exercised to reduce the risk of nuisance tripping, such as when a vehicle, trips the sensor while the gate is still moving, and 3) One or more non-contact sensors shall be located where the risk of entrapment or obstruction exists, such as the perimeter reachable by a moving gate or barrier. <p>j) For a gate operator utilizing Type B2, contact entrapment protection:</p> <ol style="list-style-type: none"> 1) One or more contact sensors shall be located where the risk of entrapment or obstruction exists, such as at the leading edge, trailing edge, and postmounted both inside and outside of a vehicular horizontal slide gate. 	<p>b) L'ouvre-barrière doit être installé uniquement sur des barrières utilisées pour les véhicules. Les piétons doivent avoir une entrée distincte. Celle-ci doit être conçue pour inciter les piétons à l'utiliser. L'accès doit se trouver dans un endroit où les piétons n'entreront pas en contact avec une barrière pour véhicules en mouvement pendant le déplacement de la barrière.</p> <p>c) Pour réduire le risque de coincement lors de l'ouverture et de la fermeture, la barrière doit être installée dans un endroit où elle est suffisamment éloignée des structures avoisinantes. Les barrières basculantes ne doivent pas s'ouvrir dans des endroits accessibles au public.</p> <p>d) S'assurer que la barrière est bien installée et fonctionne librement dans les deux directions avant d'entreprendre l'installation de l'ouvre-barrière. Ne pas trop serrer l'embrayage de l'ouvre-barrière ou la soupape de décharge de l'ouvre-barrière pour compenser une barrière mal installée, qui ne fonctionne pas correctement ou qui est endommagée.</p> <p>e) Pour un ouvre-barrière utilisant une protection contre le coincement de type D:</p> <ol style="list-style-type: none"> 1) les commandes de l'ouvre-barrière doivent être placées de sorte que l'utilisateur voit l'ensemble de la zone de la barrière lorsque cette dernière est en mouvement. 2) La plaque exigée doit être placée à côté des commandes. 3) Ne pas utiliser de dispositif de fermeture automatique (comme une minuterie, une boucle de détection ou un dispositif similaire). 4) Ne brancher aucun autre dispositif d'activation. <p>f) Les commandes permanentes destinées à l'activation par l'utilisateur doivent être situées à au moins 1,83 m (6 pi) des pièces mobiles de la barrière et à un endroit que l'utilisateur ne peut atteindre pour actionner les commandes par -dessus ou sous la barrière, ou à côté ou au travers de la barrière.</p> <p>Exception: Les commandes d'accès d'urgence accessibles au personnel autorisé seulement (p. ex. pompiers, policiers, ambulanciers) peuvent être placées n'importe où, du moment qu'elles sont en vue de la barrière.</p> <p>g) Le bouton d'arrêt, ou de réinitialisation doit être situé en vue de la barrière. L'activation de la commande de réinitialisation ne doit pas entraîner l'activation de l'ouvre-barrière.</p> <p>h) Au moins deux (2) PANNEAUX D'AVERTISSEMENT doivent être installés dans la zone de la barrière. Toutes les plaques d'avertissement doivent être visibles des personnes situées à côté de la barrière sur laquelle les plaques sont installées.</p> <p>i) Pour un ouvre-barrières utilisant un capteur sans contact pour la protection contre le coincement de type B1:</p> <ol style="list-style-type: none"> 1) Voir les instructions sur l'emplacement des capteurs sans contact pour chaque type d'application. 2) Des précautions doivent être prises pour réduire les risques de déclenchement inutile, comme lorsqu'un véhicule déclenche le capteur pendant que la barrière est encore en mouvement. 3) Au moins un capteur sans contact ou plus doit être situé où il existe un risque de coincement ou d'obstruction, comme dans l'espace que peuvent atteindre le bras et la barrière lorsqu'ils sont en mouvement. <p>j) Pour un ouvre-barrière utilisant un capteurs de contact pour la protection contre le coincement de type B2:</p> <ol style="list-style-type: none"> 1) Au moins un capteur de contact doit être situé où il existe un risque de coincement ou d'obstruction, comme sur le bord d'attaque, sur le bord de fuite et sur les poteaux montés sur l'intérieur et l'extérieur d'une barrière coulissante horizontale pour véhicules.

1.2 Instructions regarding installation cont:

English	French
<p>2) One or more contact sensors shall be located at the bottom edge of a vehicular vertical lift gate.</p>	<p>2) Au moins un capteur de contact doit être situé sur le bord inférieur d'une barrière levante verticale pour véhicules.</p>
<p>3) One or more contact sensors shall be located at the pinch point of a vehicular vertical pivot gate.</p>	<p>3) Au moins un capteur de contact doit être situé au point de pincement d'une barrière à pivot vertical pour véhicules.</p>
<p>4) A hardwired contact sensor shall be located and its wiring arranged so that the communication between the sensor and the gate operator is not subjected to mechanical damage.</p>	<p>4) Un capteur de contact doit être installé et câblé de sorte à éviter que la communication entre le capteur et l'ouvre-barrière soit gênée par des dommages mécaniques.</p>
<p>5) A wireless device such as one that transmits radio frequency (RF) signals to the gate operator for entrapment protection functions shall be located where the transmission of the signals are not obstructed or impeded by building structures, natural landscaping or similar obstruction. A wireless device shall function under the intended end-use conditions.</p>	<p>5) Un dispositif sans fil, comme un appareil qui transmet des signaux de radiofréquence (RF) à l'ouvre-barrière pour prévenir le coincement, doit être situé à un endroit où la transmission des signaux ne sera pas obstruée ou gênée par des structures, des arbres ou d'autres obstacles similaires. Un dispositif sans fil doit fonctionner dans les conditions pour lesquelles il a été conçu.</p>
<p>6) One or more contact sensors shall be located on the inside and outside leading edge of a swing gate. Additionally, if the bottom edge of a swing gate is greater than 101.6 mm (4 in) but less than 406 mm (16 inches) above the ground at any point in its arc of travel, one or more contact sensors shall be located on the bottom edge.</p>	<p>6) Au moins un capteur de contact doit être situé à l'intérieur et à l'extérieur du bord d'attaque d'une barrière battante. De plus, si le bord inférieur de la barrière battante est situé à plus de 101,6 mm (4 po), mais à moins de 406 mm (16 po) du sol à l'un des points de sa trajectoire, au moins un capteur de contact doit être situé sur le bord inférieur.</p>
<p>7) For a vertical barrier (arm) operator utilizing Type B2 contact entrapment protection, one or more contact sensors shall be located at the bottom edge of a vertical barrier (arm).</p>	<p>7) Pour un ouvre-barrière à bras levant utilisant un capteur de contact pour la protection contre le coincement de type B2, au moins un capteur de contact doit être situé sur le bord inférieur de la barrière à bras levant.</p>
<p>8) One or more contact sensors shall be located where the risk of entrapment or obstruction exists on a bifold gate, such as:</p>	<p>8) Au moins un capteur de contact doit être situé où il existe un risque de coincement ou d'obstruction sur une barrière pliante, comme :</p>
<p>i) At the inner and outer leading edge,</p>	<p>i) Au bord d'attaque intérieur et extérieur;</p>
<p>ii) Between the outer column panel and the inner bifold panel of an opening bifold gate,</p>	<p>ii) Entre le panneau de colonne extérieur et le panneau interne à deux volets d'une barrière pliante;</p>
<p>iii) Between the outer/column panel and any obstruction within 406mm (16 in) of the gate panel when it is in the fully open position,</p>	<p>iii) Entre le panneau de colonne extérieur et tout obstacle se trouvant à moins de 406 mm (16 po) du panneau de barrière lorsqu'il est en position complètement ouverte;</p>
<p>iv) At hinge points depending on the construction of the gate,</p>	<p>iv) Aux points de charnière selon la construction de la barrière;</p>
<p>v) On the bottom edge(s), if the bottom edge(s) of a bifold gate is/are greater than 152 mm (4 in) but less than 406 mm (16 in) above the ground at any point in its arc of travel.</p>	<p>v) Sur les bords inférieurs d'une barrière pliante, s'ils sont situés à plus de 152 mm (4 po), mais à moins de 406 mm (16 po) du sol à l'un des points de la trajectoire de la barrière.</p>

1.3 DoorKing 8080-057 Photocell Type B-1- INCLUDED

This retro-reflective photocell (UL 325 Type B-1) works with ALL DoorKing gate operators to comply with the 2018 UL 325 standards. It **must** be wired to the gate operator using the photocell's **NORMALLY OPEN** input so the gate operator can **monitor the photocell**. The photocell is powered by 18-32 VAC **OR** VDC from the gate operator if desired. The relay output is rated for 1 Amp @ 24 VAC **OR** VDC maximum. It **MUST** be mounted vertically as shown and not horizontally to protect it from the weather. The green LED will remain lit when the reflector is aligned correctly with the photocell. **The photocell has a max sensing range of 35 ft.**

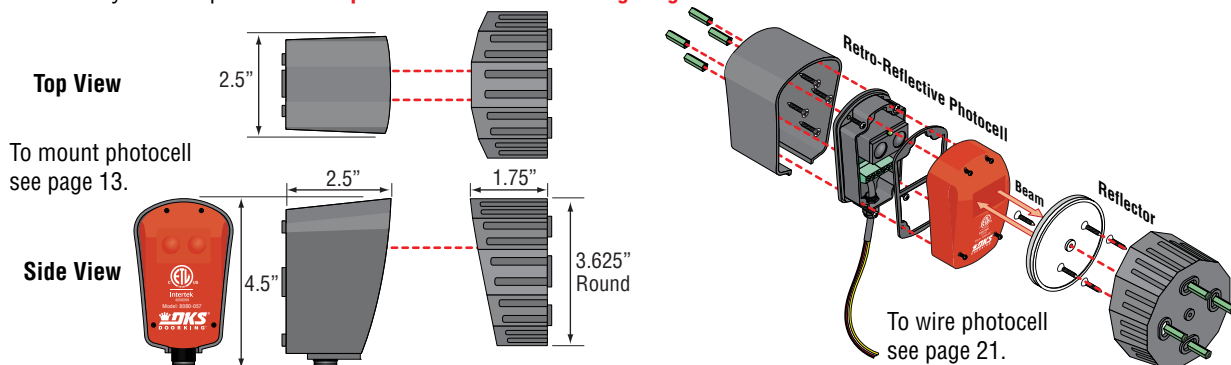

1.4 IMPORTANT Safety Information for Lane Arm Barrier System

Shut OFF Power

Service Panel

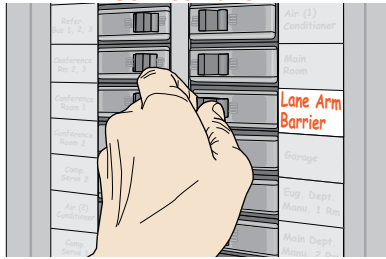

• When removing the lane arm barrier operator from service, move the arm and lane arm to the full open position and Shut-OFF AC power at the operator's AC power switch on operator's electronic box AND at the service panel.

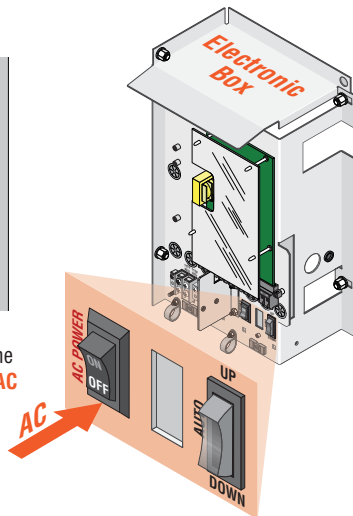

• Speed limit through barrier area is 5 MPH. Install speed bumps, warning signs and hazard stripes where visible in the area of the barrier gate, failure to do so may result in injury, damage to operator and vehicle.



• Emergency Access Controls only accessible by authorized personnel (e.g., fire, police, EMS) may be placed at any location in the line-of-sight of the barrier gate.



• Access Controls intended for user activation must be located at least six feet (6') away from any moving part of the barrier gate and where the user is prevented from reaching over, under or around the barrier gate to operate the controls. It's best to keep opening device in a SECURE area.

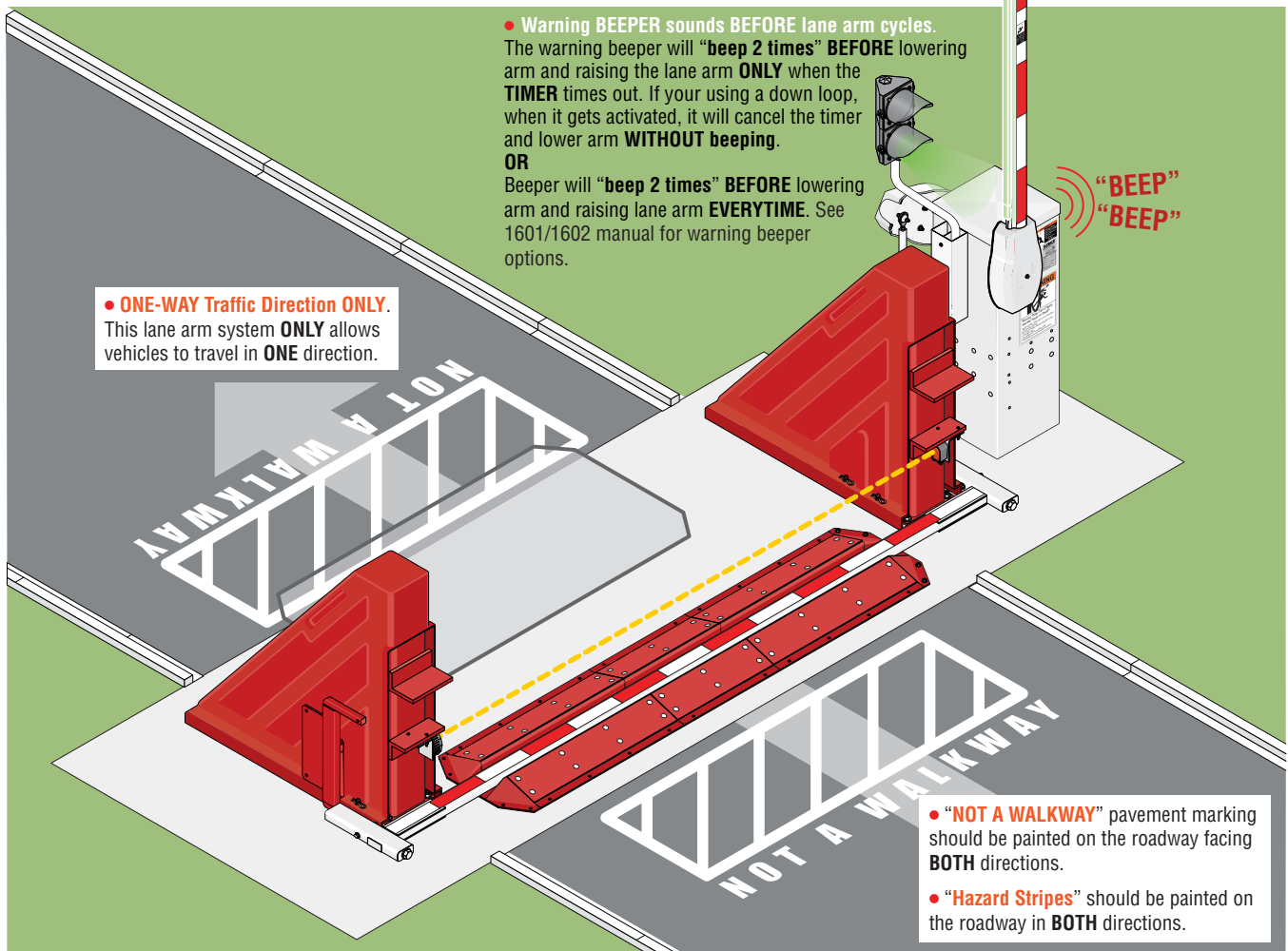

• Warning BEEPER sounds BEFORE lane arm cycles. The warning beeper will "beep 2 times" BEFORE lowering arm and raising the lane arm ONLY when the TIMER times out. If your using a down loop, when it gets activated, it will cancel the timer and lower arm WITHOUT beeping. OR Beeper will "beep 2 times" BEFORE lowering arm and raising lane arm EVERYTIME. See 1601/1602 manual for warning beeper options.

• ONE-WAY Traffic Direction ONLY. This lane arm system ONLY allows vehicles to travel in ONE direction.

• "NOT A WALKWAY" pavement marking should be painted on the roadway facing BOTH directions.
• "Hazard Stripes" should be painted on the roadway in BOTH directions.

1.4 IMPORTANT Safety Information Continued

- Pedestrians **MUST** be provided with a separate access opening.

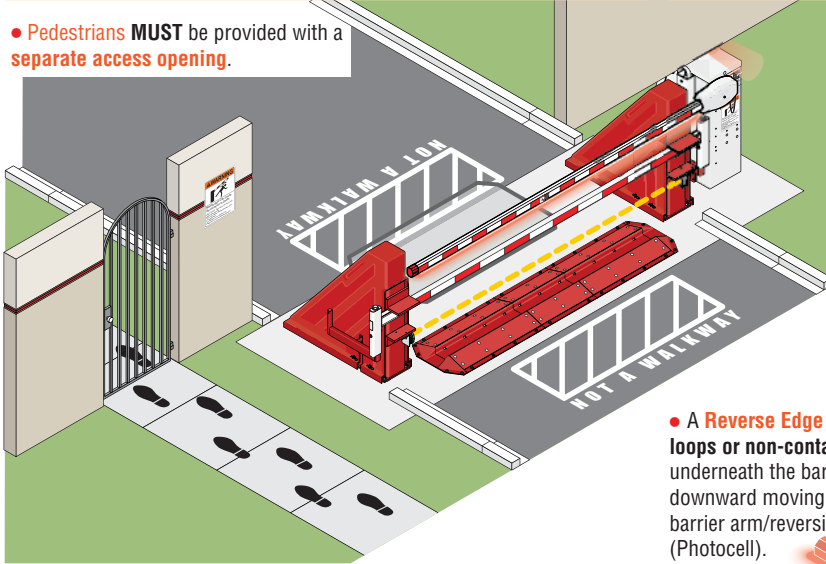

- Make sure all **WARNING SIGNS** are on operator and arm. Warning signs are to be permanently installed in the area of the gate in such a manner that at least one warning sign is visible by persons located on **each** side of the gate, for both the secure and unsecure sides of the gate.

- A **Reverse Edge** is **NOT** to be used as a replacement, or in lieu of, **in-ground loops or non-contact sensor (photocell)** that protect vehicles passing underneath the barrier arm. A moving vehicle coming in contact with a downward moving barrier arm **WILL result in damage** to the vehicle and the barrier arm/reversing edge if **NOT using in-ground loops or non-contact sensor (Photocell)**.

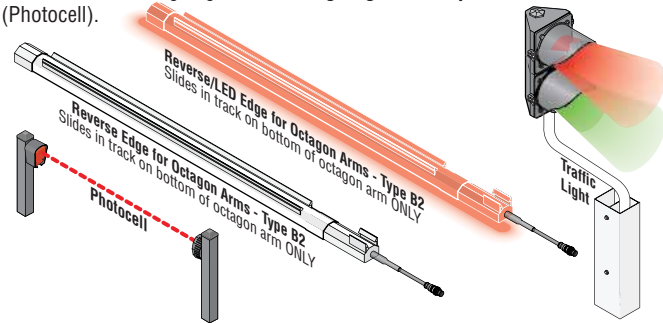

- **IMPORTANT** Keep **ALL** debris out of arm channel and from operator cabinet vents and off of arms.

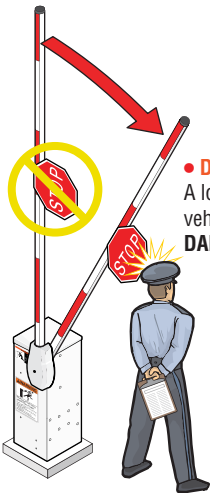

- **DO NOT** Attach **ANY** external sign on the arm. A lowering sign **WILL** cause damage to a vehicle or injure a person. This scenario is **VERY DANGEROUS** and **MUST NEVER OCCUR!!**

- **Lane Barrier System Safety Devices:** They should have **reverse/LED edge** on arm, **traffic light** and **photocell** installed. If any of these devices are **NOT** functioning, remove barrier system from service until repairs can be made.

When using a photocell, arm **will** reverse when beam gets blocked and **NOT** make contact, When **NOT** using a photocell, arm **WILL** make contact **BEFORE** reversing.

- **IMPORTANT** The barrier gate operator **CANNOT** sense a pedestrian under the raised arm **without** installing an **external safety device**. To help protect against an arm lowering on a pedestrian, **install a photocell directly under the arm**. See page 13.

- **Test the gate operator monthly.** The gate **MUST** reverse on contact with a rigid object or **stop** when an object activates the non-contact sensors. After adjusting the force or the limit of travel, retest the gate operator. Failure to adjust and retest the gate operator properly can increase the **risk of severe injury or death**.

- **Operators and components should be properly installed and maintained** following the recommended service schedule and testing the operator monthly. Keep all debris away from operator housing vents and off of arm. Contact your service dealer for any maintenance or repairs.

- **Vehicular barrier gate operators can produce high levels of force,** it is important that **you are aware** and eliminate **possible HAZARDS;** Pinch Points, Entrapment Areas, Overhead Power Wires, Absence of Controlled Pedestrian Access, Traffic Backup.

- **DKS Lane Barrier System is NOT crash rated.** It is intended to provide a formidable barrier to help prevent **passenger vehicles** and **light-duty trucks** from driving through a controlled traffic lane. A traffic light is **HIGHLY** recommended with this system.

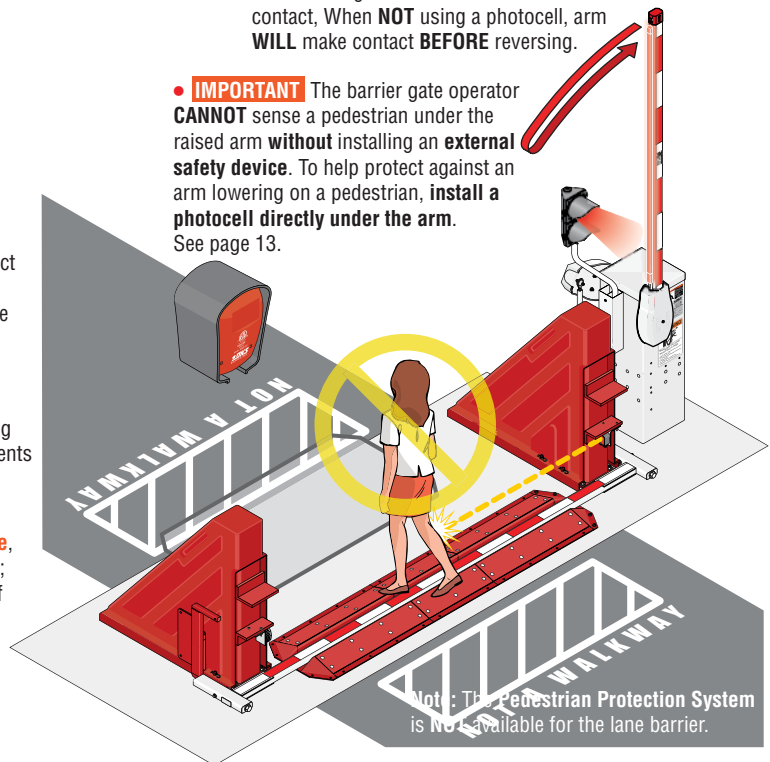

1.5 Safety and Traffic Management for Lane Barrier System

Vehicular lane barrier gate operator can produce high levels of force. It is important that you are aware and eliminate possible HAZARDS; Pinch Points, Entrapment Areas, Overhead Power Wires, Absence of Controlled Pedestrian Access, and Traffic Management.

A Separate Pedestrian Walkway

Located so pedestrians **CANNOT** come in contact with the lane barrier system.

B In-Ground Loop(s)

Loops minimize the potential of the arm closing when a vehicle is present. Number and placement of loop(s) is dependent on the application.

C Non-Contact Sensor - Photocell

(Photo Beam) Minimizes the potential of the arm or the lane arm lowering on vehicular or other traffic that loops cannot sense. **Located directly under arm.**

D Contact Sensor - Reverse Edge

Minimizes the potential of the arm lowering on vehicular or other traffic that loops cannot sense.

Contact Sensor Note: A reverse edge is **NOT** to be used as a replacement, or in lieu of, in-ground loops or non-contact sensor (Photo Beam) that protect vehicles passing underneath the barrier arm. A **moving** vehicle coming in contact with a downward moving barrier arm **WILL** result in **damage to the vehicle** and the barrier arm/reversing edge if **NOT** using in-ground loops or non-contact sensor (Photo Beam).

E "BEEP BEEP" BEFORE Cycling Arm

Used to alert pedestrians that barrier arm is about to cycle. See 1601/1602 Owner's manual 1601-065.pdf for warning beeper options.

K Traffic Red/Green Light

Helps control traffic.

L Speed Limit Sign

Helps control traffic.

F Warning Signs



Permanently mounted on **operator** and **arm** and easily visible. Warning signs are to be **permanently installed** in the area of the gate in such a manner that at least one warning sign is visible by persons located on each side of the gate, for both the **secure** and **unsecure** sides of the gate.

G Pedestrian Alert Warning:

"NOT A WALKWAY" pavement marking facing **BOTH** directions, permanently painted **WHITE** on pavement.

H Hazard Stripes

NO stopping or standing "Hazard Stripes". Permanently painted **WHITE** on pavement on both sides of arm.

I Arm LED Lights

Helps with arm's visibility and position.

J Speed Bump

Helps increase distance and time between vehicles.

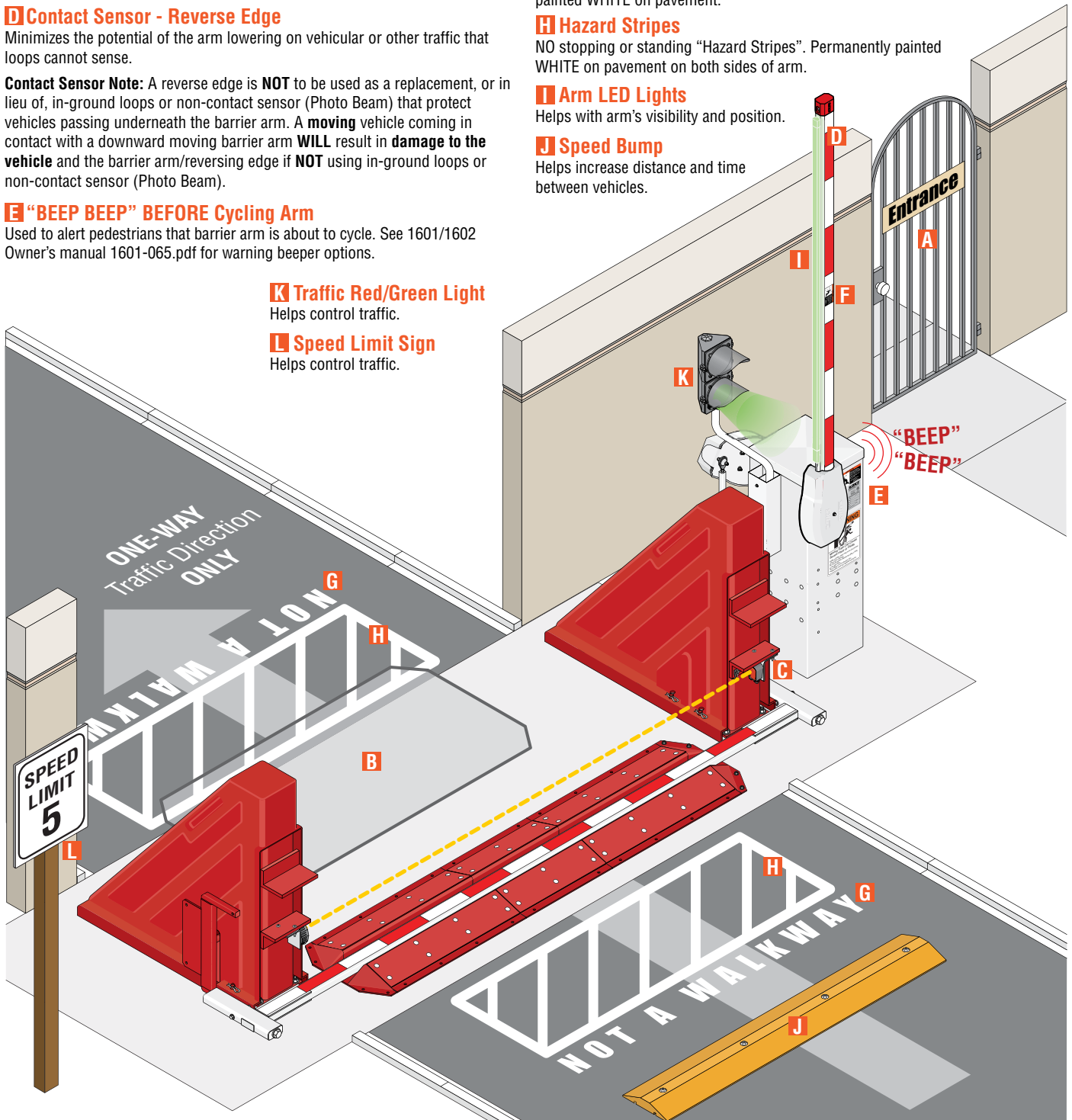

Lane Barrier One-Way Operation

Lane Barrier in **secure** position.

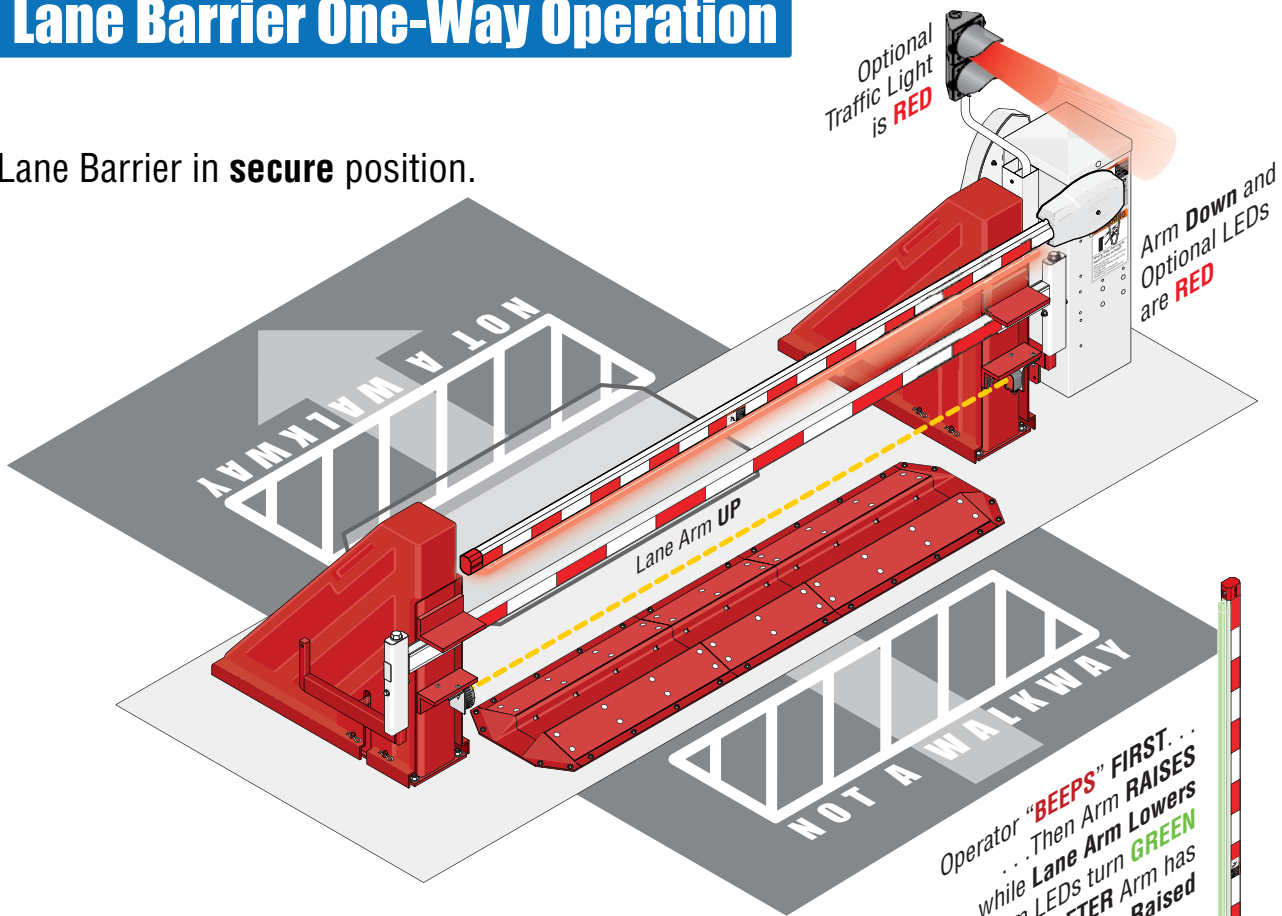

Operator "**BEEPS**" **FIRST**...
... Then Arm **RAISES**
while Lane Arm **LOWERS**
Optional Arm LEDs turn **GREEN**
AFTER Arm has
completely **Raised**

After access control device has approved entry

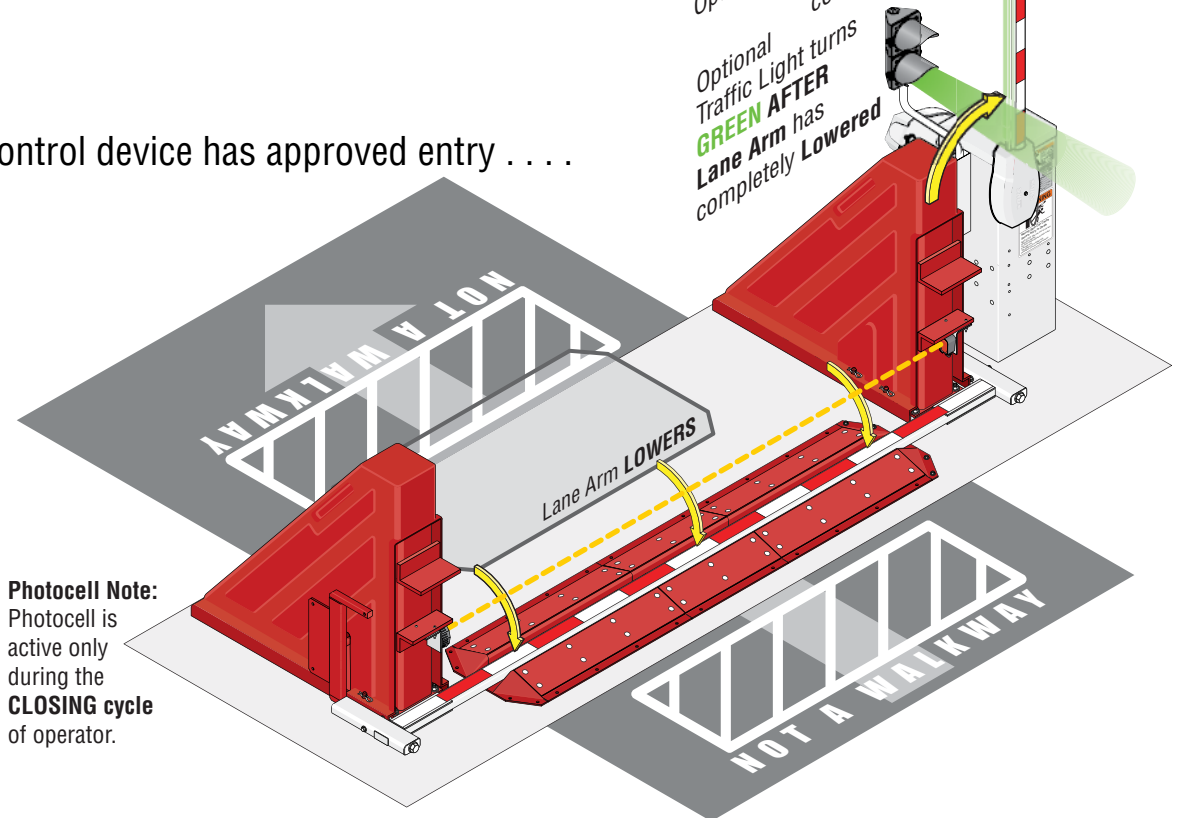

After traffic has cleared, arm LEDs and traffic light turn **RED**, arm lowers and lane arm raises.

SECTION 2 - CONCRETE SETUP OPTIONS

EXISTING concrete

WARNING for Precast Concrete: Drilling into precast concrete is **NOT recommended** without professional advice or assistance. If you don't know where the prestressed wire strands are located, you risk damaging the structural integrity of the precast concrete and the drilling equipment you use. If you need to drill into precast concrete to anchor the lane barrier to it, you must contact the building engineer before proceeding.

NEW Concrete Pad

Select which side of lane barrier the operator will be installed on (manual shows installation on the **RIGHT side** of lane barrier). To install operator on **LEFT side** of lane barrier, simply flip operator measurements to the **opposite side of concrete pad**.

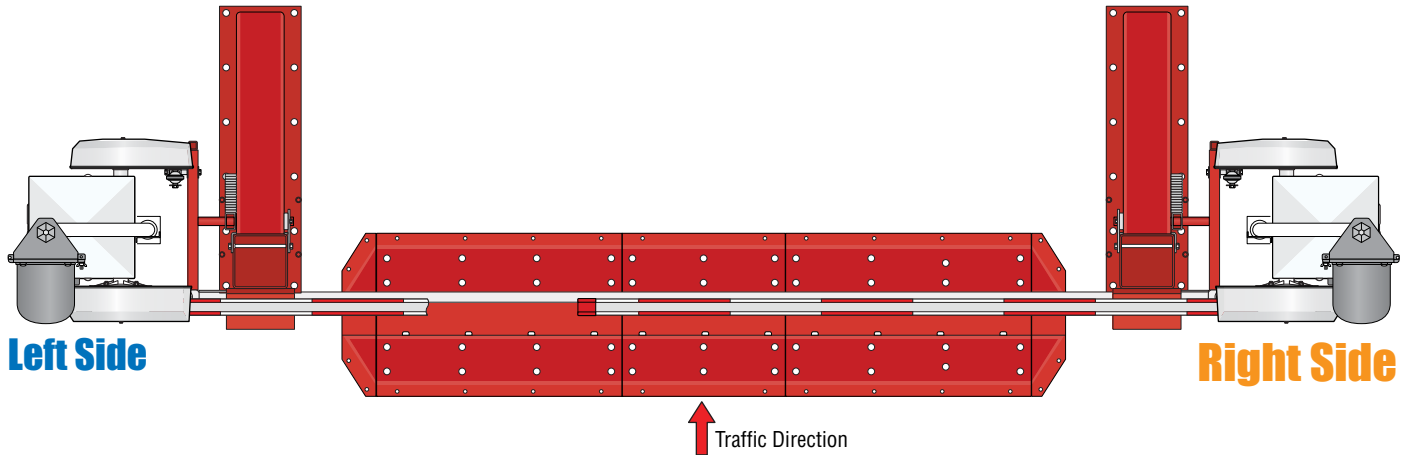

Concrete Requirements and Dimensions

- Concrete Pad 4,000 PSI. At least 6" deep.
- Soil compression under and around the foundation shall be compacted to a soil density of 95% of standard ASTM-698.
- Add gravel where necessary to insure a **solid base**. Soil must be stable and able to support the weight of the concrete pad.
- The 1620 Lane Barrier must be installed on a **flat and level concrete surface on grade with the roadway surface**.
- Place one layer **rebar mat** at eight (8) inch on-center. Use #5 (5/8 inch) Grade 40 or better.
- Cure concrete properties 4000 psi (minimum) with smooth finish and proper drainage.
- Heating element should be considered for areas with freezing temperatures.

9 ft Wide Lane Model - 14' 3"

10 ft Wide Lane Model - 15' 3"

12 ft Wide Lane Model - 17' 3"

14 ft Wide Lane Model - 19' 3"

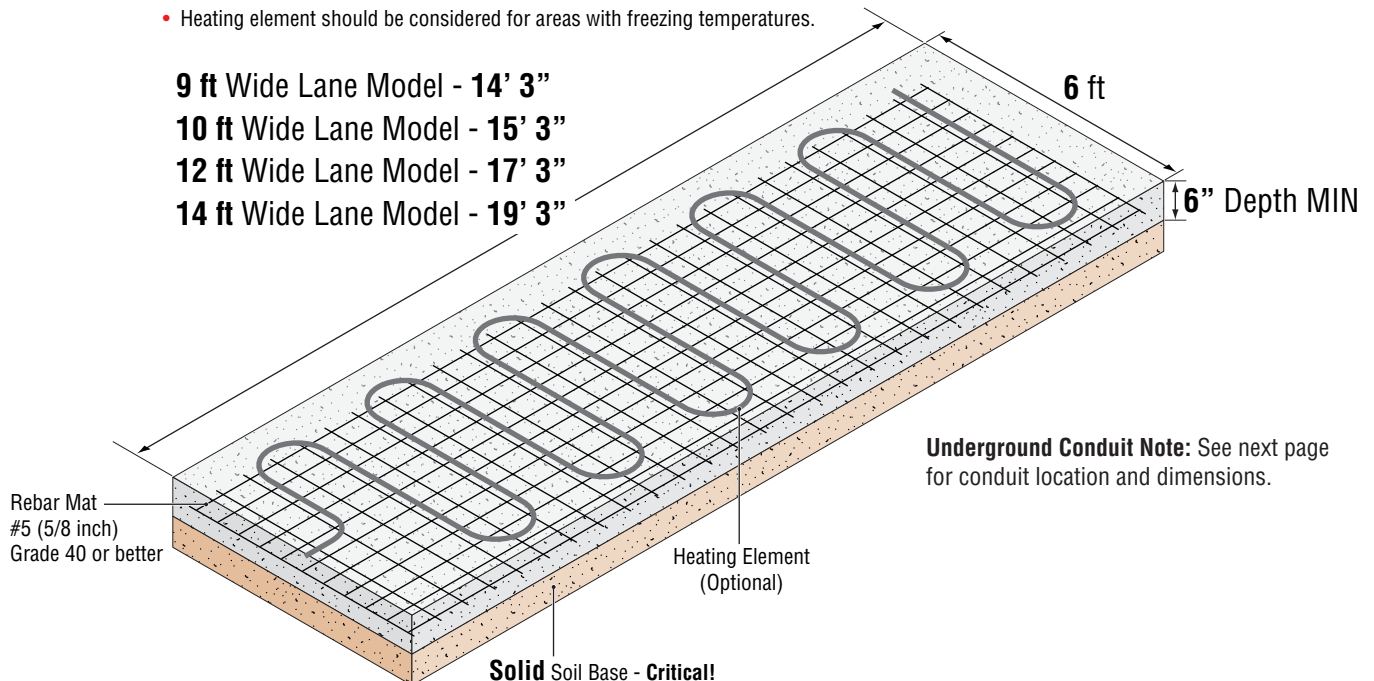

2.1 Underground Conduit

- The conduit requirements are for a typical barrier gate operator installation. The conduit requirements for your application may vary from this depending on your specific needs.
- Use only sweeps for conduit bends. **Do not use 90° elbows as this will make wire pulls very difficult and can cause damage to wire insulation.**
- DoorKing recommends using 3/4-inch conduit.

Conduit Options:

- AC Power
- Low Voltage Accessories
- Earth Ground
- Vehicle Loops
- Photocell

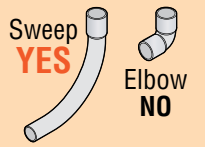

DO NOT mount photocell **UPSIDE DOWN**. Water could be an issue.

- Be sure that all conduits are installed in accordance with local codes.
- **Never** run low voltage rated wire insulation in the same conduit as high voltage rated wire insulation.

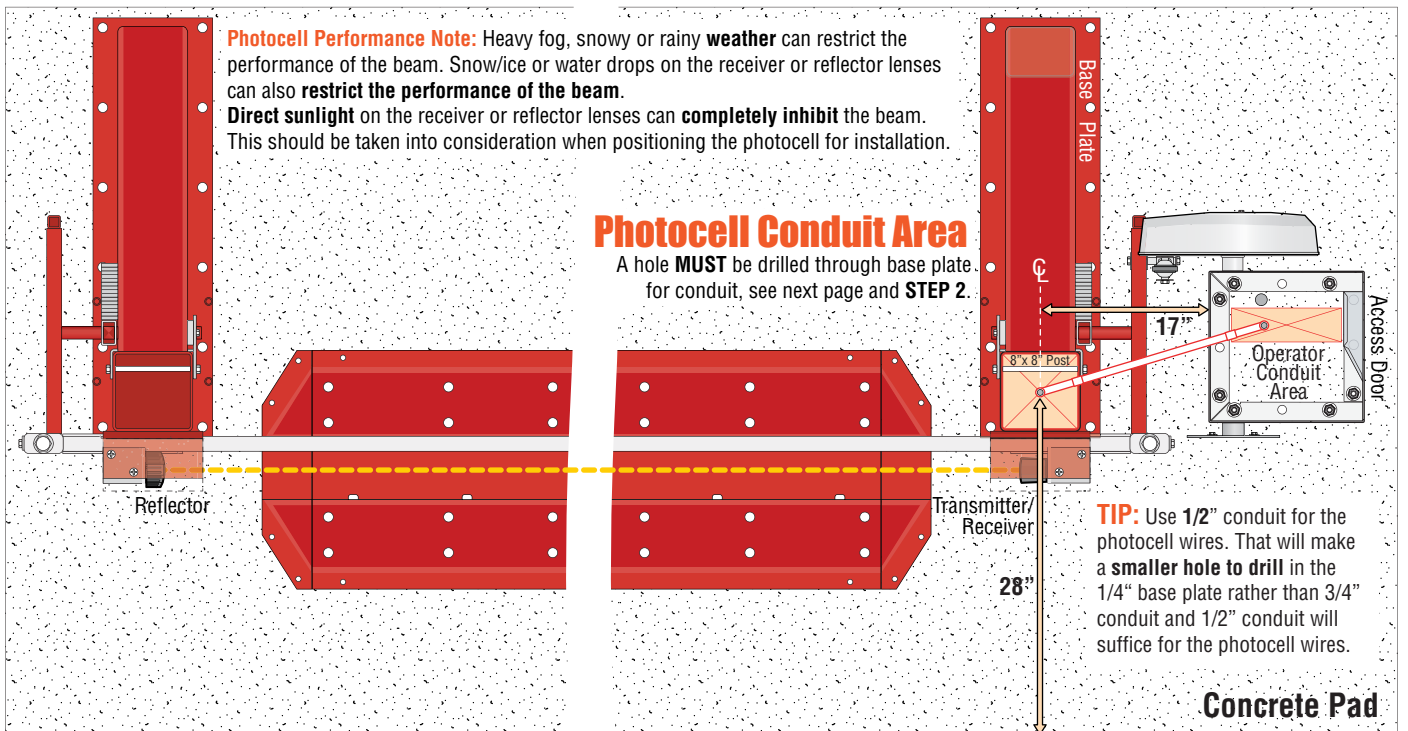
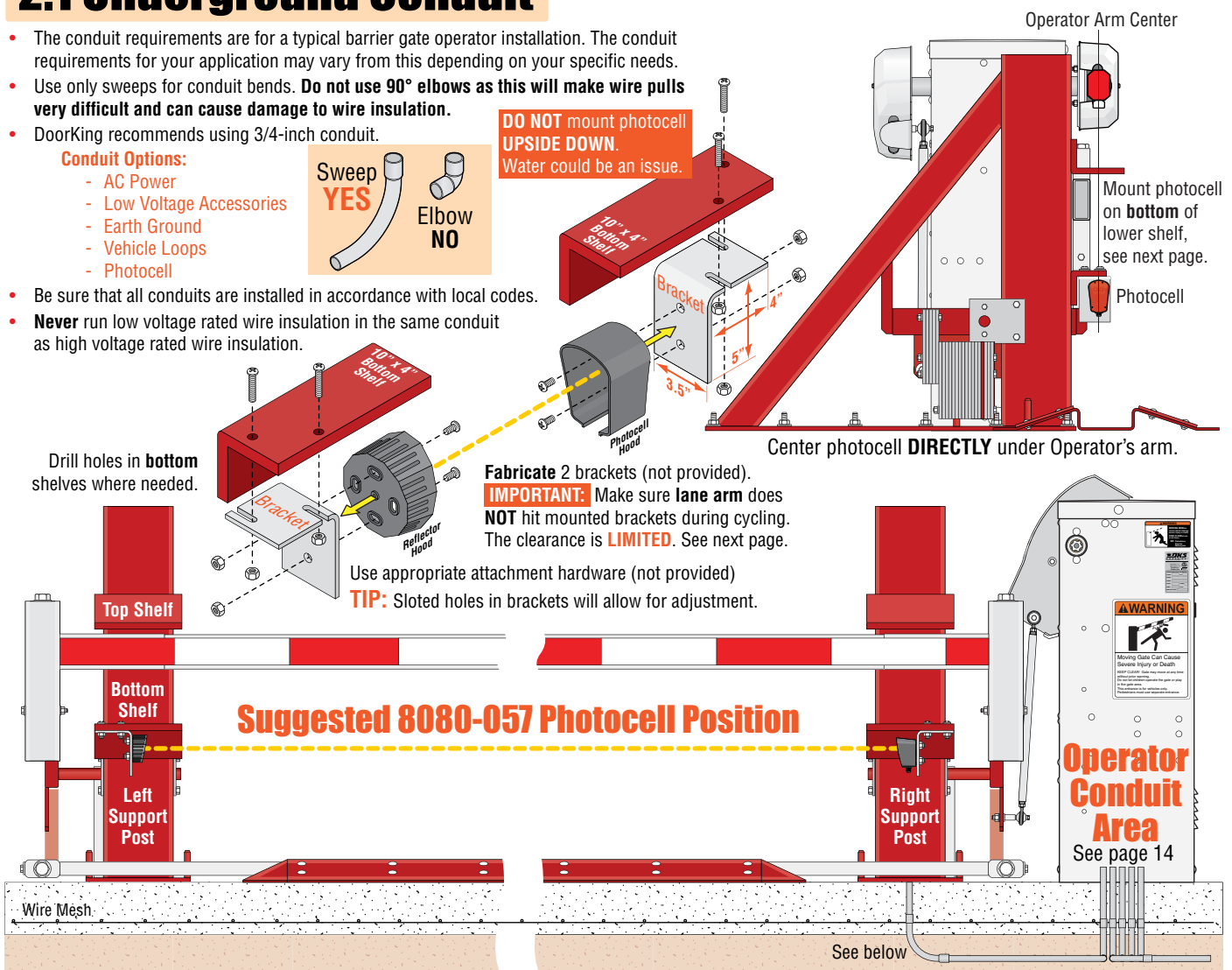

Suggested 8080-057 Photocell Position cont

Photocell & Reflector Positions

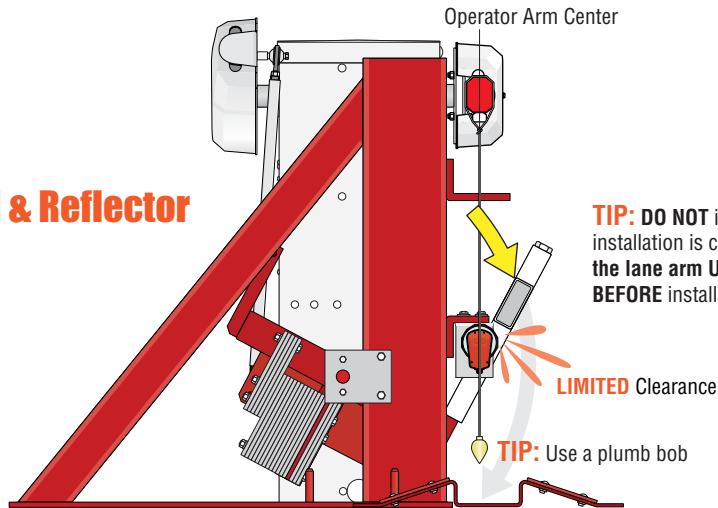

Suggested Underground Conduit Layout for a DOWN Loop (Optional)

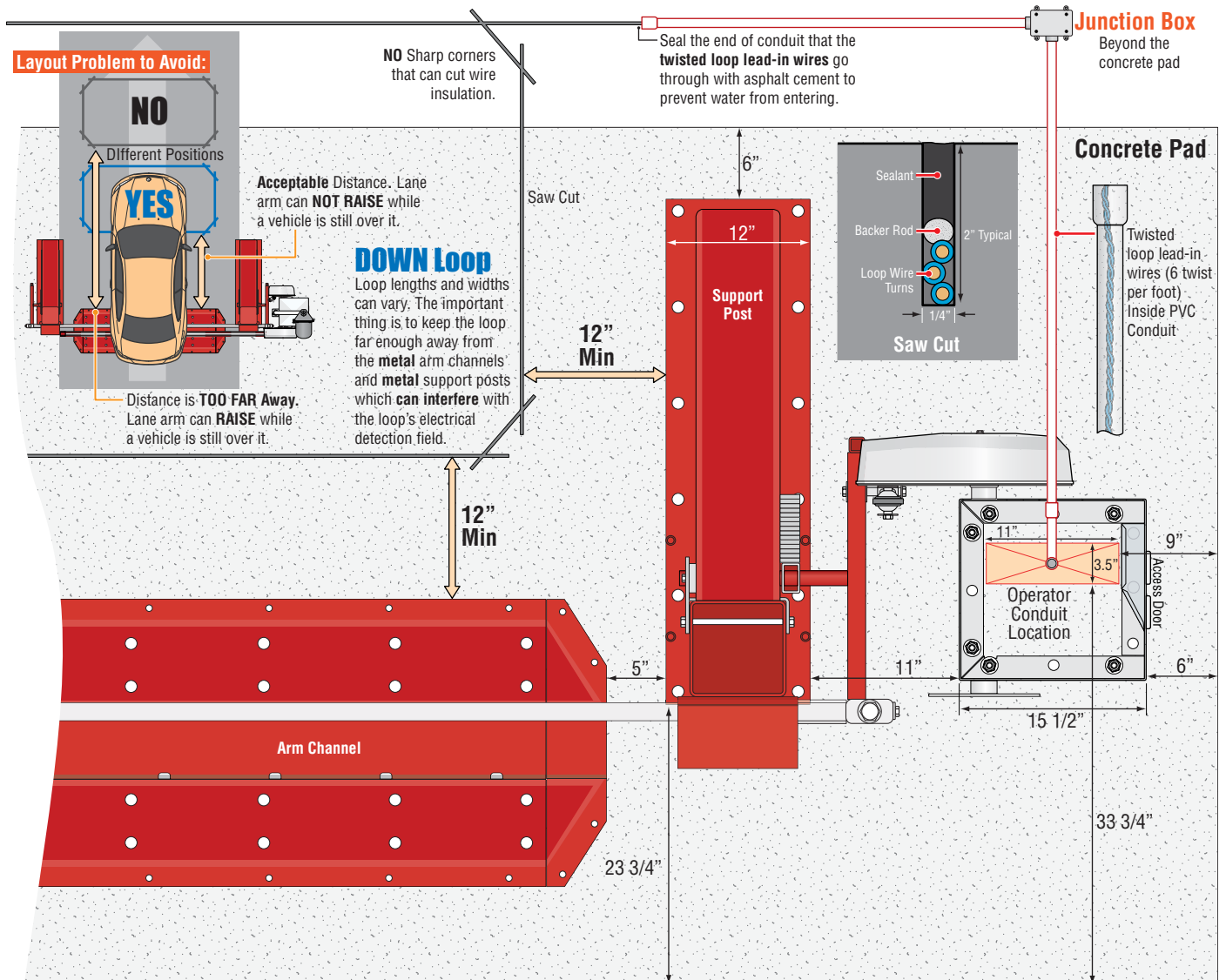

SECTION 3 - MOUNTING OPERATOR AND LANE BARRIER STEPS

1 Permanently Mount Operator

Permanently mount operator using the **CRITICAL** measurements (see previous page).

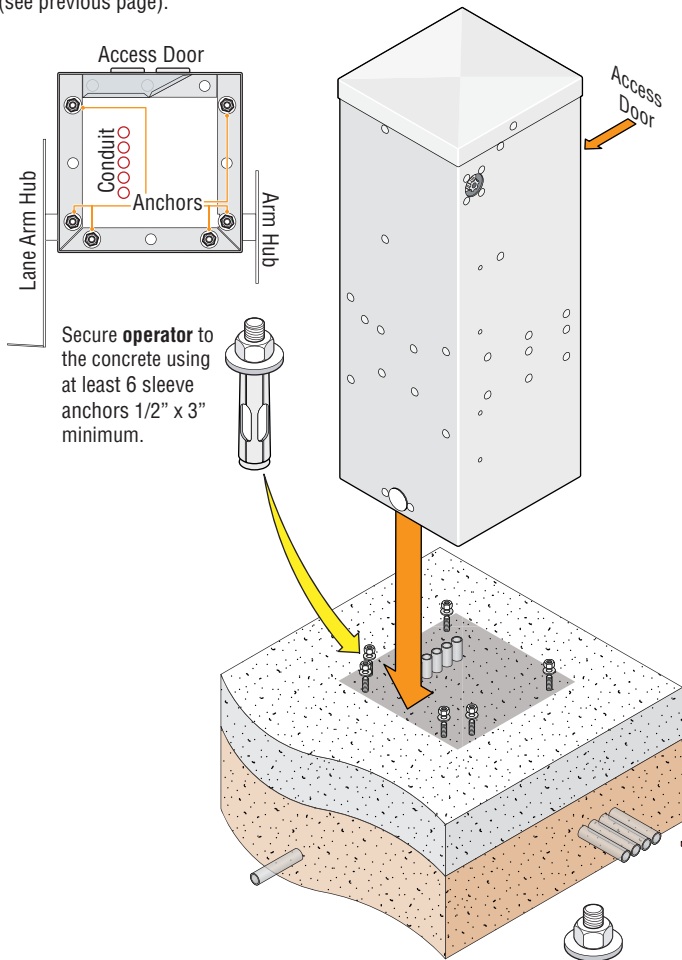

The installation shown has the operator mounted on the **RIGHT SIDE** of the lane barrier but the operator can be mounted on **either side** of the lane barrier by flipping **CRITICAL** measurements to other side of concrete pad (see previous page).

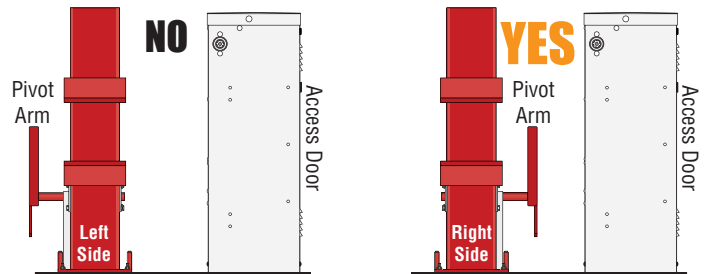

IMPORTANT Pivot arm **MUST** be positioned on operator side of support post.

2 Permanently Mount Support Post Next to Operator

Drill a hole from the **bottom of the 1/4" base plate** inside the 8" x 8" post big enough for the photocell conduit to run through (see previous page).

Permanently mount support post next to operator using 1" x 6" **stainless steel** sleeve anchors (7/8" x 6" minimum) in **specific** position on the concrete pad using the **CRITICAL** measurements (see page 8).

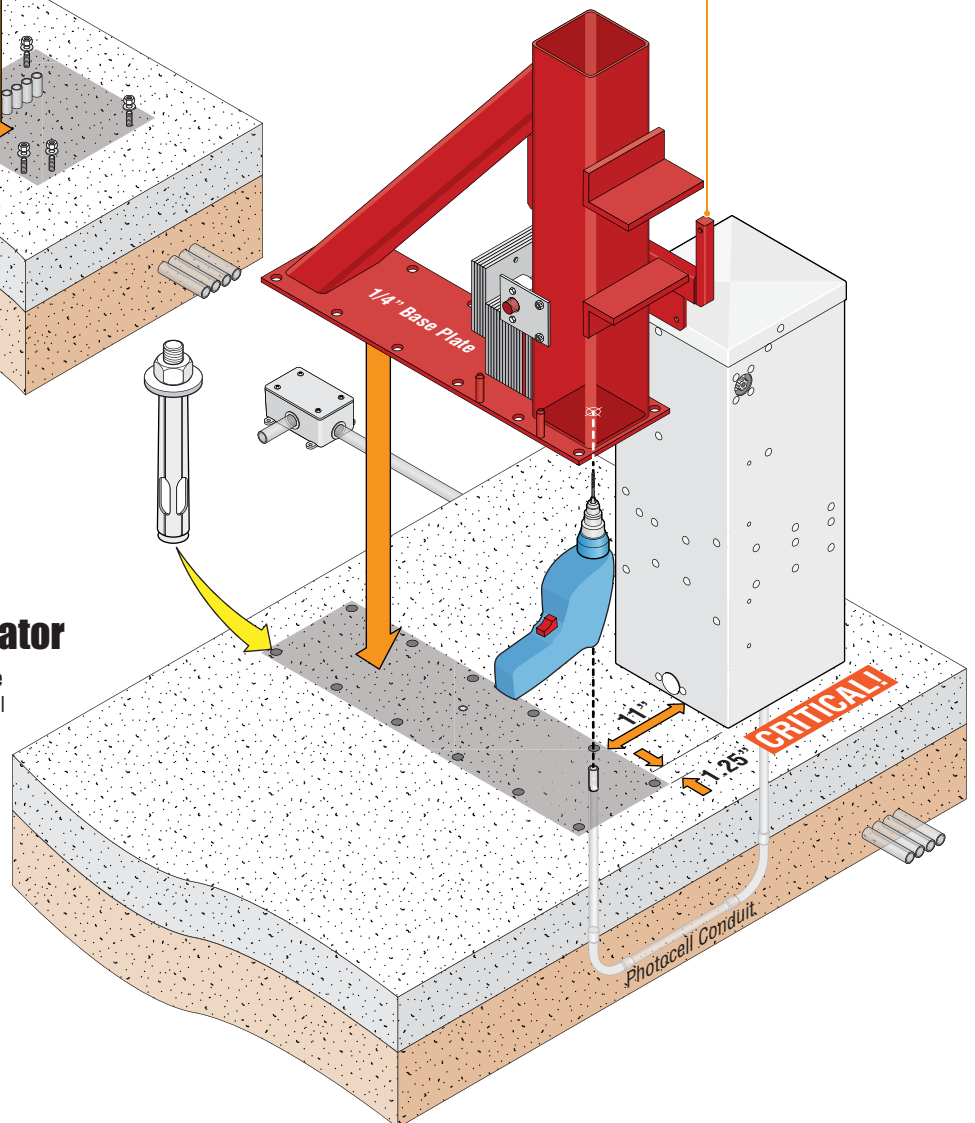

3 Bolt Lane Arm on Support Posts

Position the other support post approximately where it will be located on concrete pad. Bolt the lane arm to the support posts (see page 6 for **specific** support post lane widths depending on the model lane barrier you have chosen).

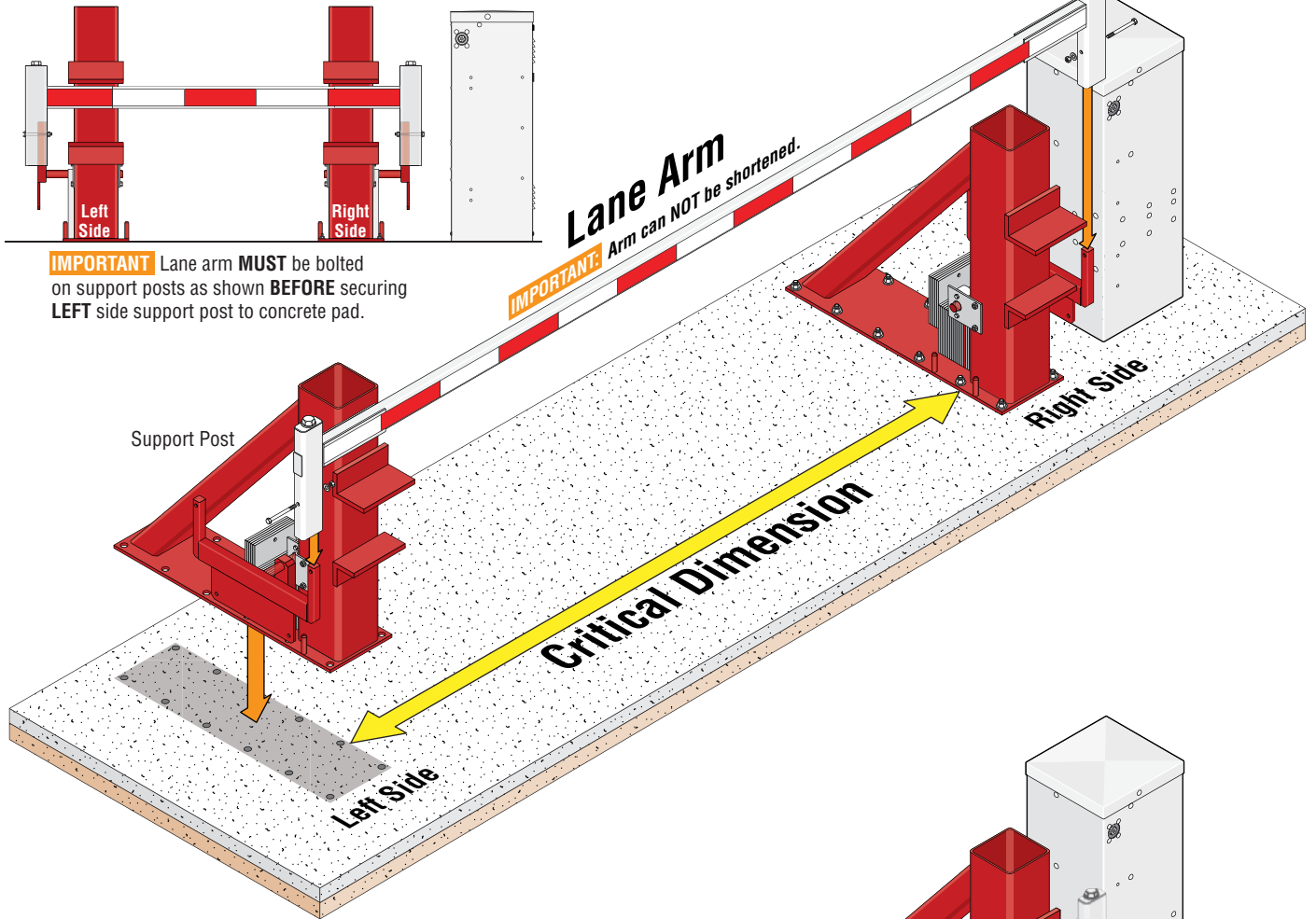

4 Permanently Mount other Support Post

After bolting lane arm to support posts, make sure lane arm is 90° with each support post. Rotate arm up and down until **satisfied** with arm operation, then permanently mount support post using 1" x 6" stainless steel sleeve anchors (7/8" x 6" minimum).

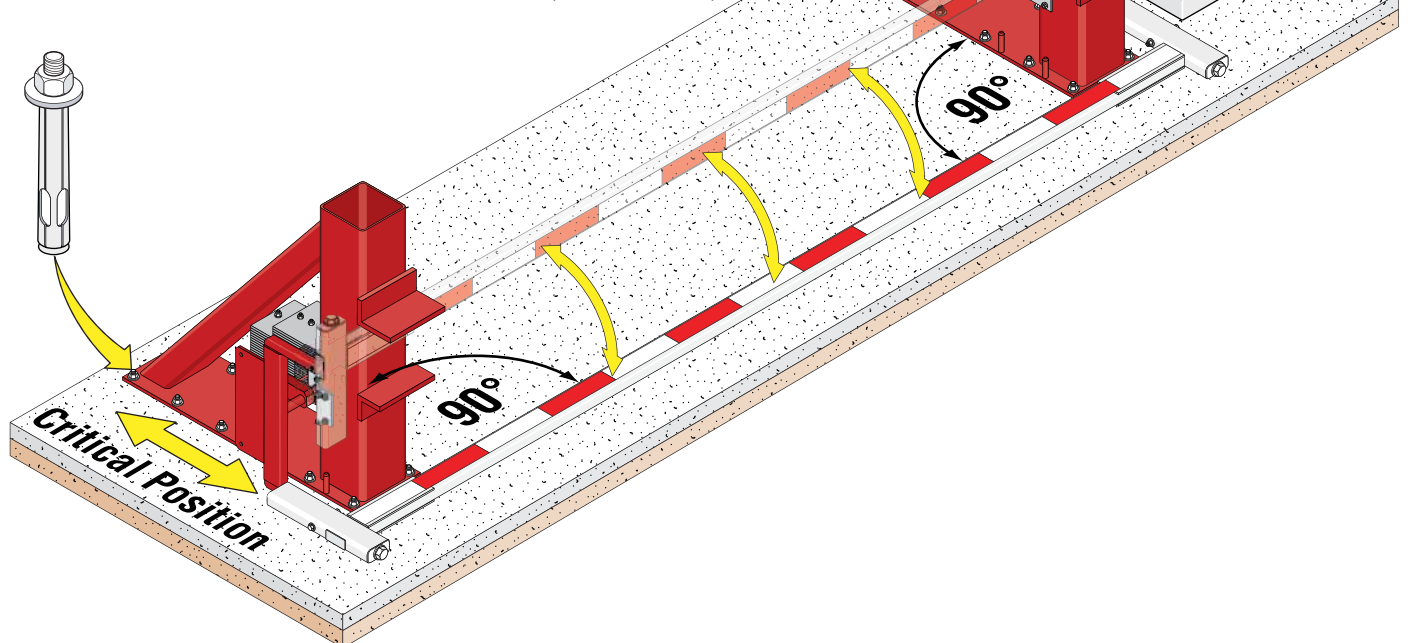

5 Permanently Mount Arm Channels

Place arm channels in position on concrete pad and center them between support posts (see page 6 for **specific** number, size and positions of channels depending on the model lane barrier you have chosen).

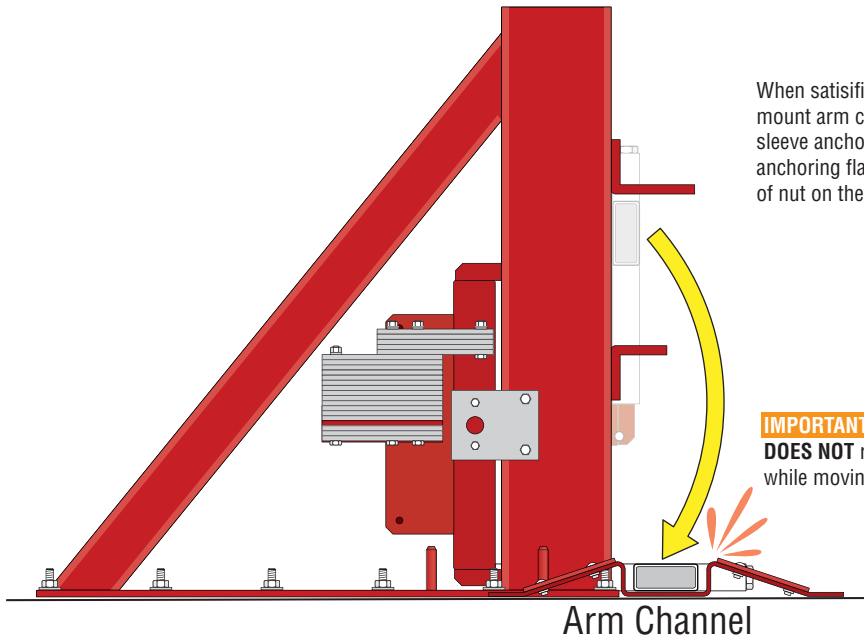

When satisfied with arm channel positions, permanently mount arm channels using 5/8" x 5" **stainless steel** sleeve anchors (1/2" x 5" minimum) using **every hole** on anchoring flange. Cut off excess threads flush with top of nut on the sleeve anchors to prevent tire damage.

IMPORTANT Make sure lane arm **DOES NOT** rub the arm channels while moving arm **UP** and **DOWN**.

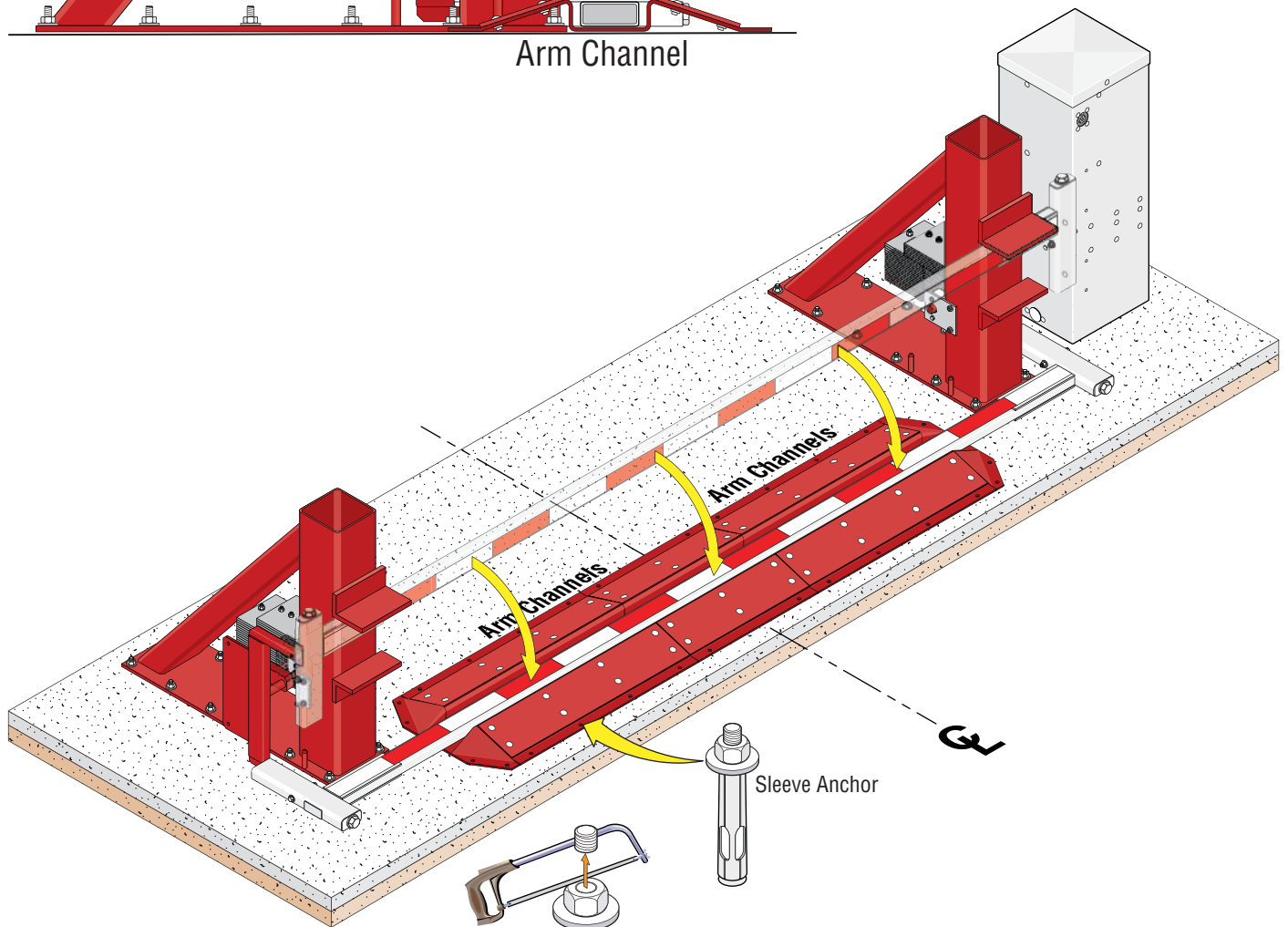

Cut off excess threads flush with top of nut on the sleeve anchors to prevent tire damage.

6 Connect Operator to Lane Arm

Connect lane arm shaft to the pivot arm in hole shown using hardware provided.

IMPORTANT
Operator power is **REQUIRED** for this step, see below.

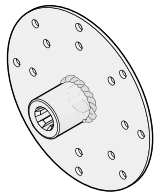
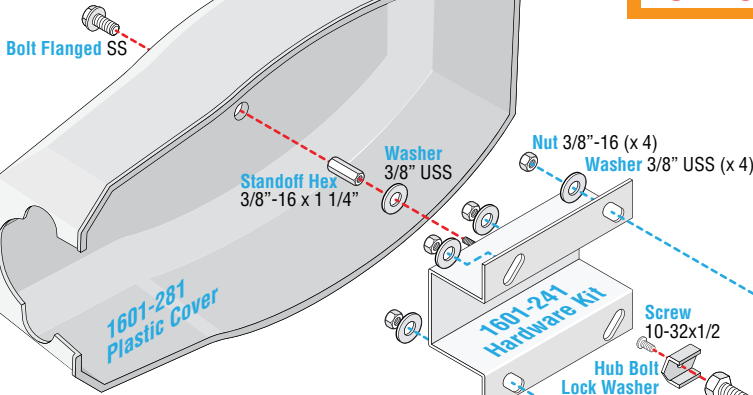

1601-241 Kit Note: Kit comes with a standard arm hub that is **NOT** used.

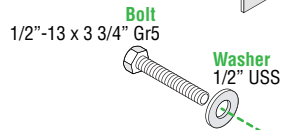

IMPORTANT Test the Lane Arm Hub's **UP** and **DOWN** positions **BEFORE** installing it.
TURN OFF POWER BEFORE INSTALLING

TIP: Make all connections but the final bolt connection to the lane arm hub as indicated. Cycle the operator to see the lane arm hub's "OPEN" and "CLOSE" positions while raising and lowering the lane arm shaft **BY HAND** to see if any interference occurs **BEFORE** making the **FINAL CONNECTION** to the hub. If there is interference, adjust hub position and lane arm shaft nut adjustments accordingly until satisfied with lane arm operation, **then** make the final bolt connection to the lane arm hub.

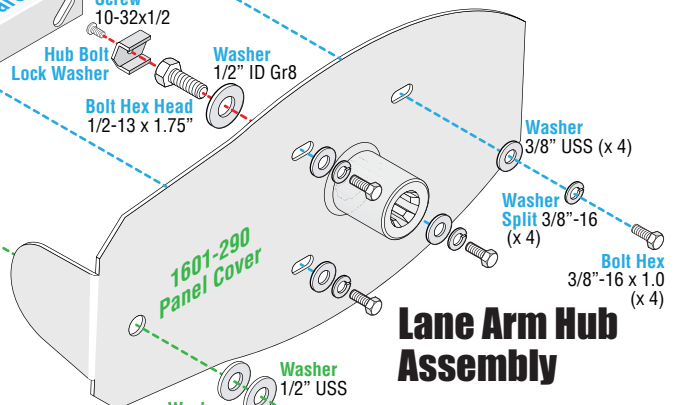

Lane Arm Hub Assembly

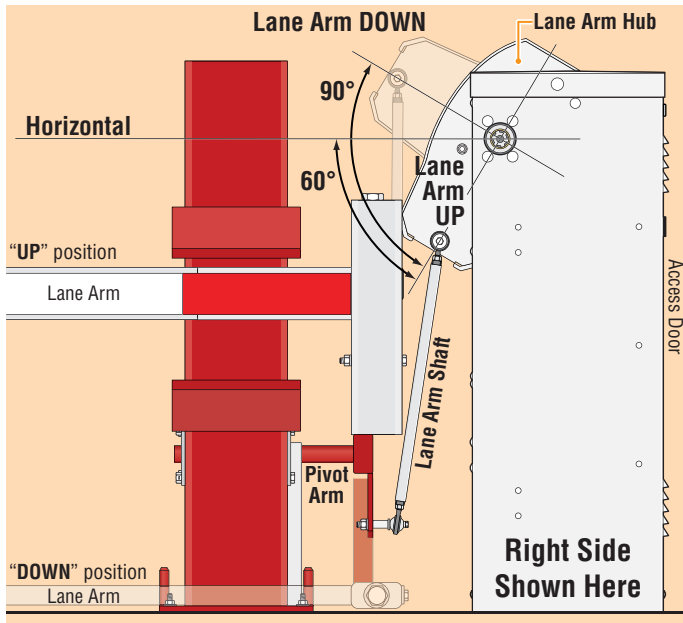

Lane Arm Shaft Assembly

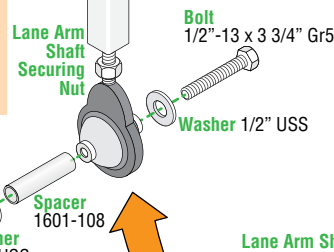

FINAL CONNECTION

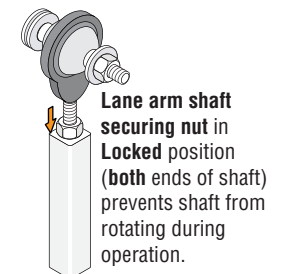

Note: Operator will require power when performing this step. Refer to 1601 manual for power wiring info.

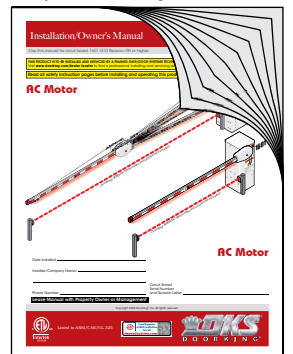

1601/1602
Installation/Owner's
Manual - 1601-065.PDF

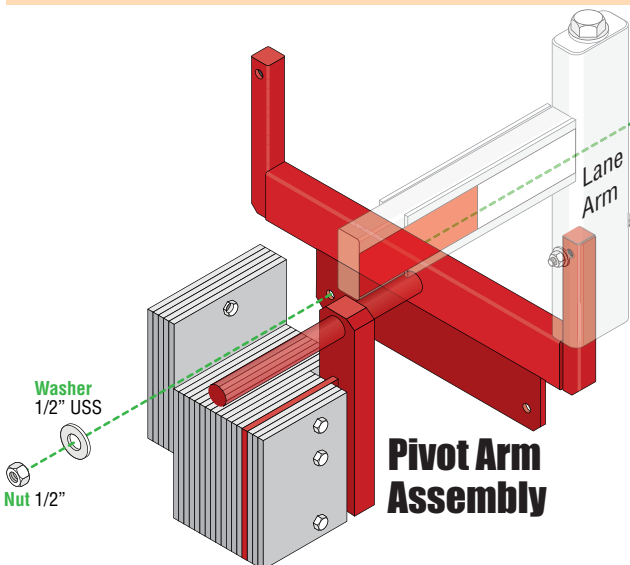

Pivot Arm Assembly

7 Install Covers

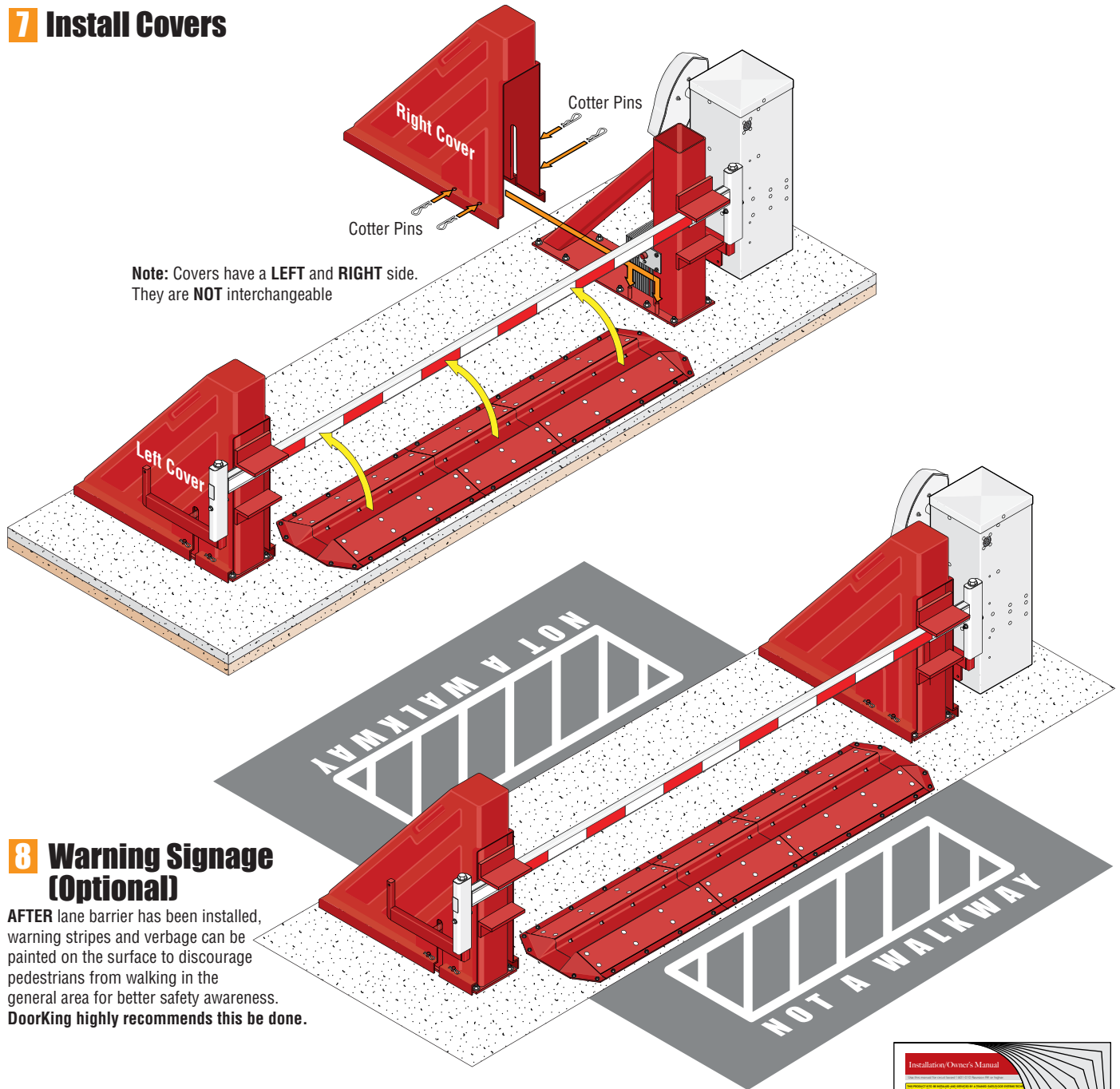

8 Warning Signage (Optional)

AFTER lane barrier has been installed, warning stripes and verbage can be painted on the surface to discourage pedestrians from walking in the general area for better safety awareness. DoorKing highly recommends this be done.

9 Install Arm and OPTIONAL Traffic Light

Install YOUR Chosen arm, see instruction sheet that comes with it. The OPTIONAL traffic light can be installed and is HIGHLY recommended, see instruction sheet that comes with it.

The necessary OPERATOR wiring connections, DIP-switch settings, adjustments, and operator maintenance are found in the 1601 Barrier Manual and will be needed to COMPLETE the installation.

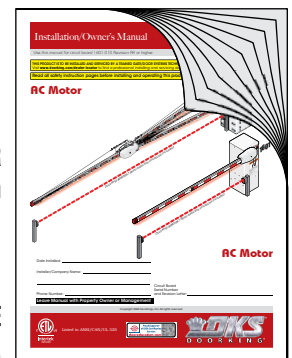

1601/1602 Installation/Owner's Manual - 1601-065.PDF

Regular Maintenance of Lane Barrier System

Regular inspection and removal of trash, debris, gravel, and rock is required in order to keep lane barrier functioning properly. Neglecting to regularly clean trash and debris **out of arm channel** is the number one cause of breakage and malfunctions.

Make sure all moving parts are functioning normally. If they are NOT, remove lane barrier from service immediately until it can be repaired.

SECTION 4 - PHOTOCELL

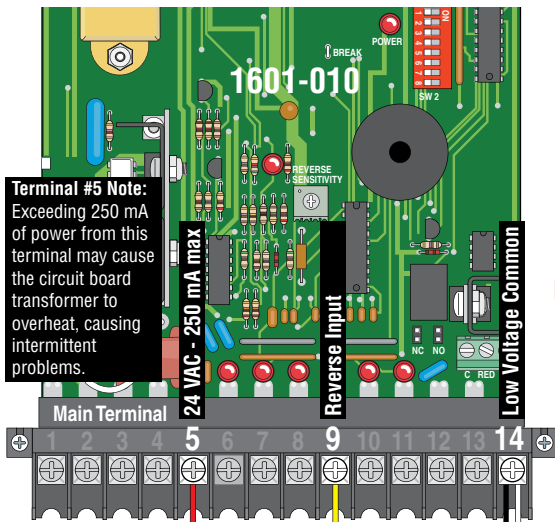

Terminal #5 Note:
Exceeding 250 mA of power from this terminal may cause the circuit board transformer to overheat, causing intermittent problems.

**DoorKing
Retro-Reflective
Photocell
(P/N 8080-057)**



Yellow - (NO)

White - Com

Black - Com

Red - 24V

DIP-Switch

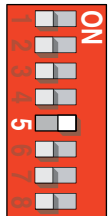

SW 2

SW 2, Switch 5 is **ON**. The lowering arm will **instantly reverse** when photocell gets blocked.

Type of wiring to be used on ALL external devices:
A) Type CL2, CL2P, CL2R, or CL2X.
B) Other cable with **equivalent or better** electrical, mechanical, and flammability ratings.

Fine Tune Photocell

After photocell has been mounted, spring mounted beam sensors can be precisely adjusted "Fine tuned" using the 3 screws to help keep the **GREEN LED ON** if necessary.



Extra wire cable will be needed to connect the photocell. Use a flexible **copper** four wire **22 AWG** min. cable.

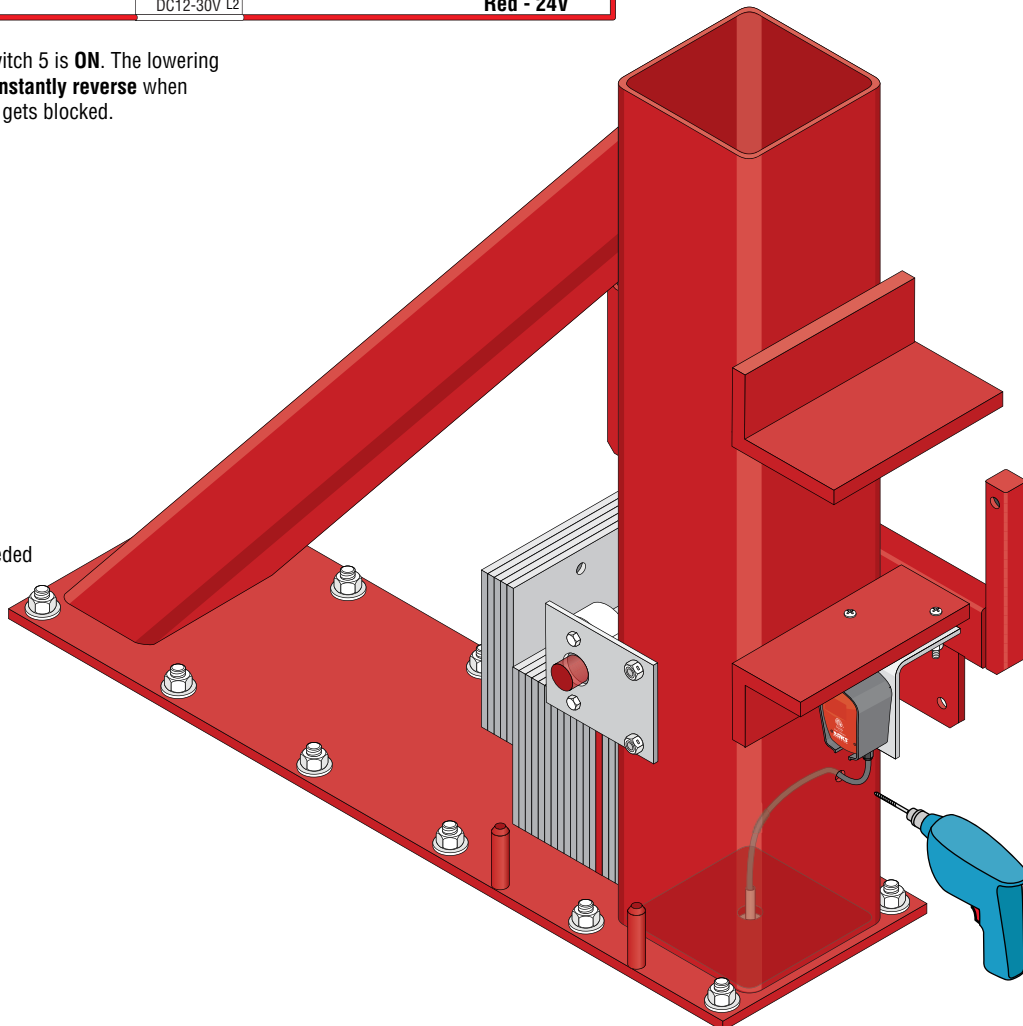

Drill hole in 8" x 8" post to run wire through.

SECTION 5 - IN-GROUND LOOP OPTIONS

Type of wiring to be used on ALL external devices:
A) Type CL2, CL2P, CL2R, or CL2X.
B) Other cable with equivalent or better electrical, mechanical, and flammability ratings.

Typical DIP-Switch Settings

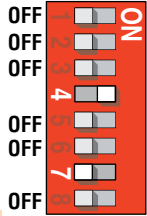

SW 1

Switch 4 is **ON**.

Switch 7 is **OFF** (Timer). The arm will rotate down after the vehicle clears the **down loop**. See timer note below.

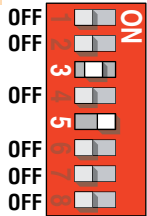

SW 2

Switch 3, see next page.

Switch 5 is **ON**. The lowering arm will **instantly reverse** when photo sensor gets blocked.

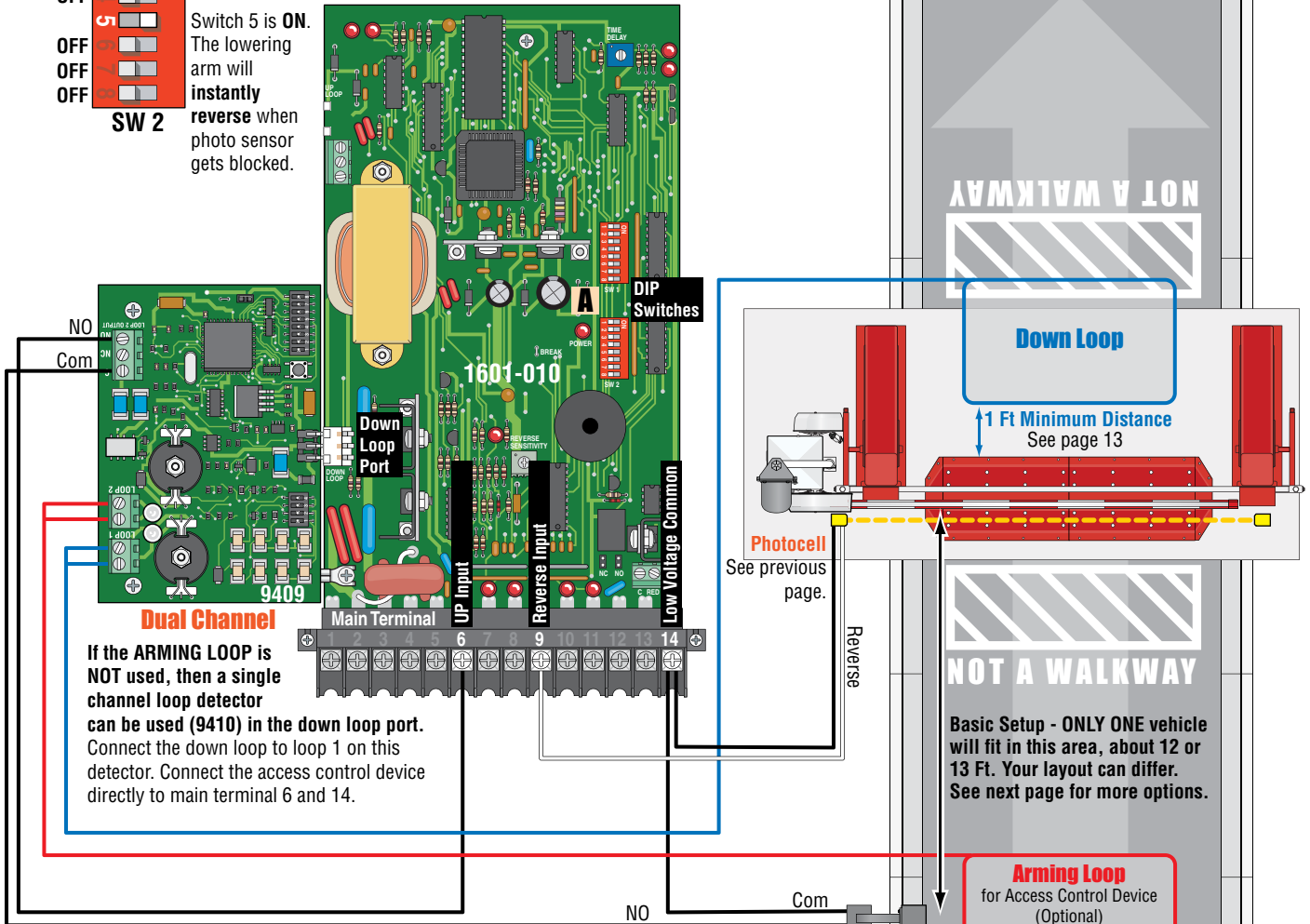

Before attempting to connect any wiring to the operator, be sure that the circuit breaker in the electrical panel is in the OFF position. Permanent wiring must be installed to the operator as required by local electrical codes. It is recommended that a licensed electrical contractor perform this work.

Loop detector wiring shown is for DoorKing model 9409 Dual Channel plug-in loop detector only. If using other loop detectors refer to their Loop Information Manual for installation instructions, loops/preformed loops and wiring diagrams. All inputs to the main terminal are **NORMALLY OPEN**.

DoorKing offers a free "Loop and Loop-Detectors Information Manual" PDF located at DoorKing's web site for more information. www.doorking.com

Arming Loop Note: The arming loop **only** allows the access control device to function when a vehicle is on the loop, otherwise it will not function. This prevents pedestrians from gaining access through the vehicular gate.

Timer Note: The timer can be used with a down loop. When timer is ON with a down loop, it will start countdown when the arm has fully raised. Activation of the down loop will cancel timer countdown. Useful when an access control device **OR** ticket spitter has been activated but vehicle does not move forward to activate the down loop. **The arm will remain UP.** Timer will time out and lower the arm **without** the down loop being activated.

SW2 DIP-Switch 3 - Override DOWN Loop Commands Layouts

The **BASIC UP/DOWN** operation of an operator using a **DOWN LOOP** will raise the arm when a valid UP command is received and lower the arm **AFTER** the vehicle clears the **DOWN LOOP**. **NO** additional valid UP commands will be accepted during this process. **AFTER** the arm lowers, another UP command will be accepted and so on. This is a **SLOW** process during heavy traffic periods. A **FASTER ENTRY PROCESS** uses the **SW2 DIP-Switch 3 ON/OFF** options to allow the **Access Control Device** and the **Lane Barrier System** keep the arm **RAISED** between **UP** commands **OR** control **MULTIPLE** valid UP commands during the arm cycling, allowing the arm to **remain raised** while **vehicles** enter the property, speeding up the entry process by a considerable amount using either option. This is very desirable during heavy traffic periods and decreases the wear and tear on the lane barrier components. The layouts below show typical **distance restriction** for each option, **YOUR** layout may vary.

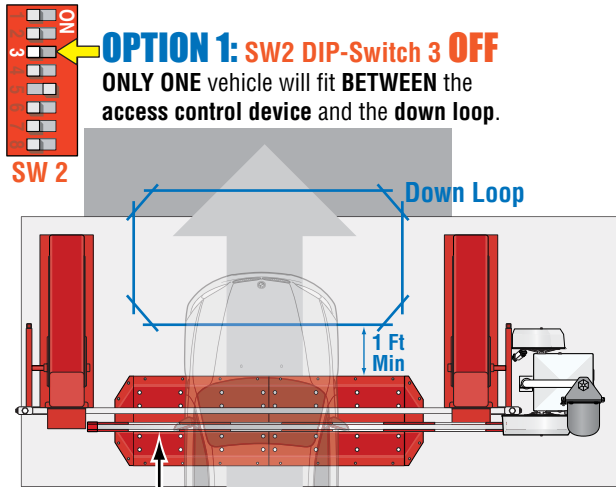

OPTION 1: SW2 DIP-Switch 3 OFF
ONLY ONE vehicle will fit **BETWEEN** the access control device and the down loop.

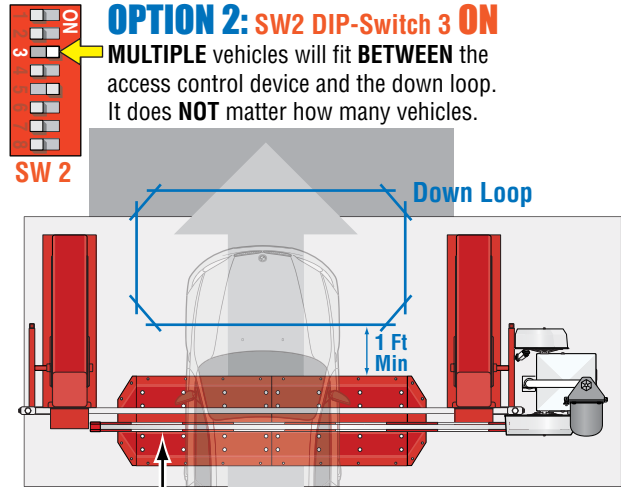

OPTION 2: SW2 DIP-Switch 3 ON
MULTIPLE vehicles will fit **BETWEEN** the access control device and the down loop. It does **NOT** matter how many vehicles.

DOWN LOOP MUST BE USED

See page 13

~12'

Access Control Device

With this option, the operator will **NOT** accept **another** valid UP command **UNTIL** "1st vehicle" **ACTIVATES** the down loop. After accepting the **second** UP command, arm will **remain RAISED** until 2nd vehicle **activates** down loop and so on, **ONE** vehicle at a time.

Option 1 ONLY controls **ONE** vehicle at a time. It **WILL NOT** keep track of **multiple** vehicles Up commands.

Remote transmitters are recommended for this option. If remote is accidentally pressed multiple times, it will **ONLY** be counted **ONCE**.

Note:

If a valid **UP command** is given while the system is **closing**, the system will reverse **instantly** and **open** with either option.

Distance will vary depending on the number of vehicles that can fit between access device and down loop

This option allows the access control device and the barrier gate operator to have **multiple vehicles** in the area in-between them. The operator will **IMMEDIATELY** accept and **count all the valid UP commands** received. It requires a **down loop activation for each one**, but the arm **remains RAISED** during this process. The arm will lower **ONLY ONCE** after the **LAST** vehicle clears the down loop.

Remote transmitters are **NOT** recommended for this option because **one vehicle's remote** can accidentally be pressed **multiple times** which will get counted by the operator as multiple vehicles.

Option 2 WILL keep track of **multiple** vehicles Up commands. It does **NOT** matter how many vehicles.

SECTION 6 - MANUAL RELEASE OPTIONS

FACTORY Installed Manual Release Procedure

- 1 Unlock and remove access door.
- 2 Remove crank tool from inside access door.
- 3 Flip interlock assembly door up, power will be disabled from operator.
- 4 Insert crank tool into motor pulley as shown.
- 5 Rotate crank tool to manually move operator arm **UP** or **DOWN**.

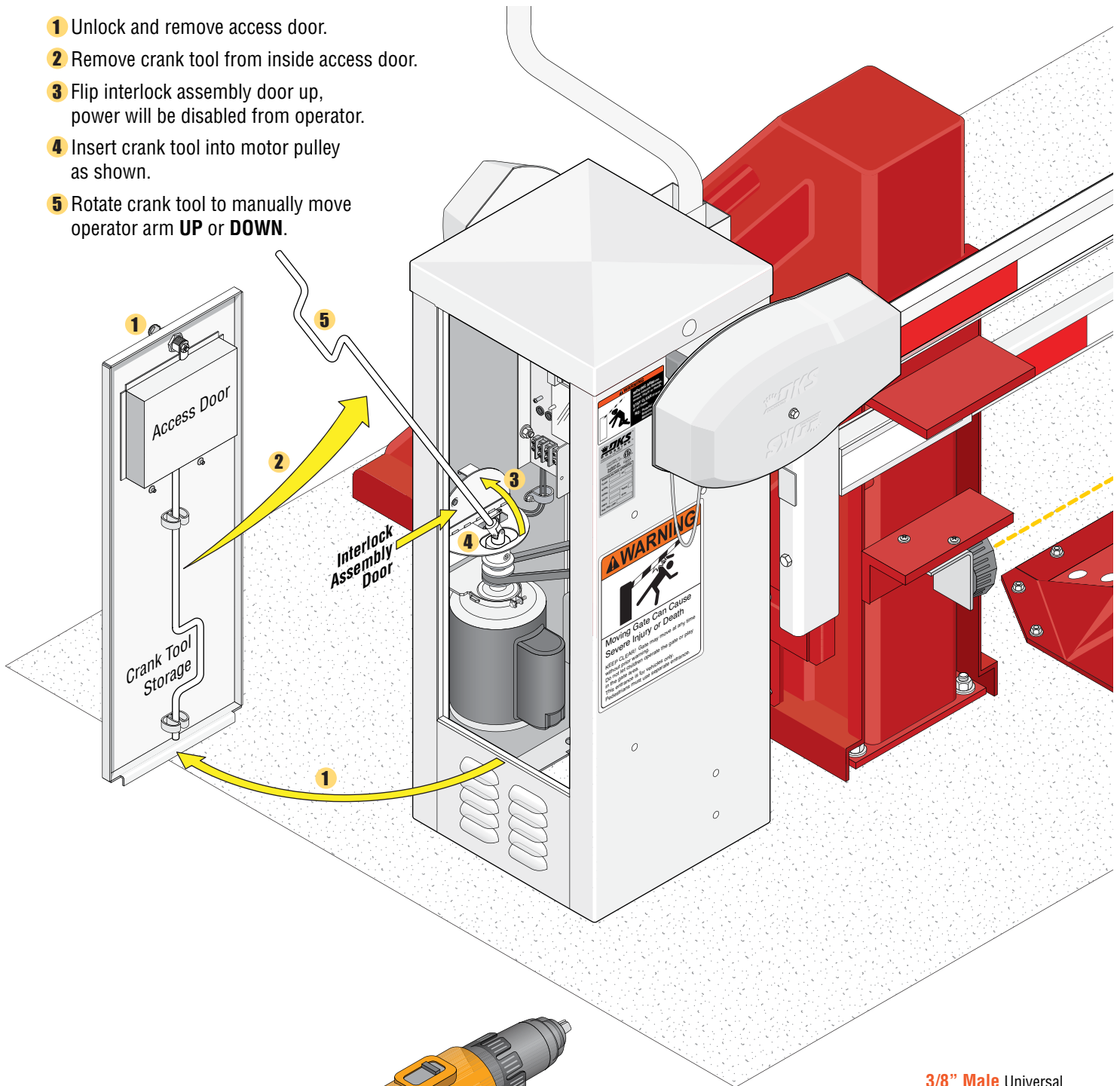

A **Cordless Drill** can be used to manually crank the arm and wedge.

BE CAREFUL if using a cordless drill.

Take it slow, **damage could occur**. DoorKing does **NOT** recommend using a cordless drill because of damage that **could** occur.

Hardware **NOT** provided.

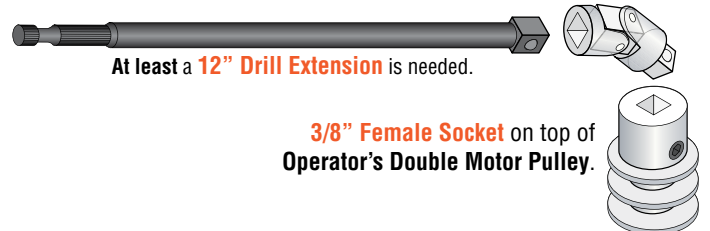
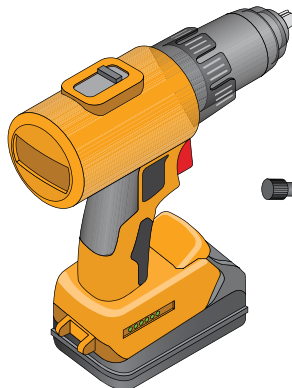

At least a **12" Drill Extension** is needed.

3/8" Male Universal Joint Socket Adapter is needed.

3/8" Female Socket on top of Operator's Double Motor Pulley.

Installation Manual

1620 Lane Barrier

Surface Mount Vehicular Lane Barrier System

Use this manual for circuit board 1601-010 Revision AK or higher.

1620-065-V-6-26

The 1620 lane barrier is NOT a stand-alone product.
It MUST be used with a 1603-580 Barrier Gate Operator (sold separately).



WARNING pre-stressed concrete may be used in multi-level parking garages. Cutting a tensioned cable, or tendon, can endanger the contractor and compromise the structural integrity of the floor. Contact the building structural engineer for specific instructions and information BEFORE drilling or saw cutting into the floor.

INSTALLATION AND USE OF THE LANE BARRIER IN AREAS SUBJECT TO FREEZING WEATHER WITH POTENTIAL FOR SNOW AND ICE ACCUMULATION IS NOT RECOMMENDED.

THIS PRODUCT IS TO BE INSTALLED AND SERVICED BY A TRAINED GATE/DOOR SYSTEMS TECHNICIAN ONLY.
Visit www.doorking.com/dealer-locator to find a professional installing and servicing dealer in your area.

www.doorking.com

The 1620 is not crash rated. It is intended to provide a more formidable barrier in conjunction with a standard barrier arm operator system.
The 1620 is ideally used to control passenger vehicles and lightduty trucks.

DoorKing, Inc.
120 S. Glasgow Avenue
Inglewood, California 90301
U.S.A.

Phone: 310-645-0023
Fax: 310-641-1586