

# 2108 eVolve

## VIDEO ENTRY SYSTEM

### Voice or Video calling and access management from anywhere with the DKS Cloud



**2108 eVolve**  
Surface Mount

- The 2108 eVolve is an advanced and versatile Video Entry System, allowing the homeowner or system users the ability to grant entry to guests even from thousands of miles away.
- The 2108 features Video or Voice calls in a broadcast mode for up to 4 phones simultaneously when the call button is pushed.
- Available with built-in paper directory for 12 names
- The 2108 control dashboard is browser based, so all that's needed is an internet connection and a web browser to access Entry System settings such as users, access time zones, entry codes and more.
- Residents can quickly grant guests access from their home phone or smartphone.
- Able to control up to three entry points, the 2108 eVolve operates with an internet connection or an optional cellular connection.

Internet Connection - Wired or Wireless



eVolve Technology Inside

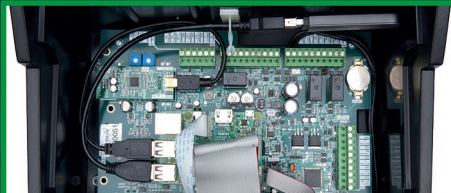

**Wireless Cellular Connection Option**  
Use if an internet connection is not possible.



**Internet Connection**  
Use your existing internet connection for easy Plug & Play connectivity



**Live Video Streaming**  
Users with the DKS video calling app downloaded to their smartphone are able to communicate with guests via video stream



**Voice Communication**  
Talk to guests at a front door or gate from any telephone in the home, or mobile phone



**Broadcast Calling**  
Access requests from the call button can ring up to 4 phones simultaneously.



**Control from Any Device, Anywhere**  
Administrators can access system settings from any browser via the cloud.

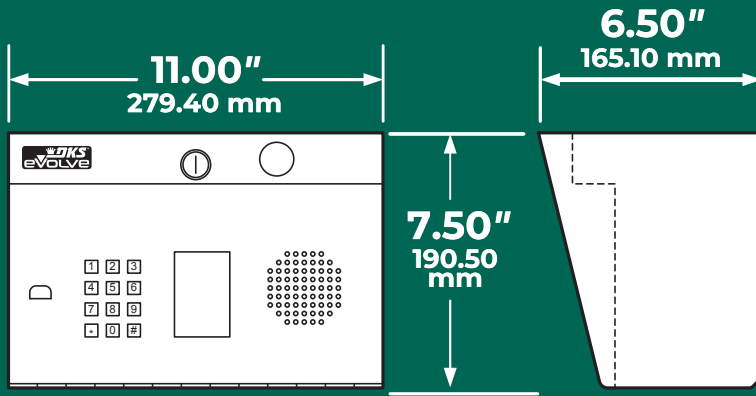

**2108 eVolve**  
Surface Mount  
w/Directory

MODEL	2108
PHONE NUMBERS	10 Residents, four (4) phone numbers per resident
ENTRY CODES <sup>1</sup>	Programmable to four (4) or five (5) digits
RELAYS	Three (3) Type C

1. Entry codes grant access when entered on the system keypad

**TECHNICAL FEATURES**

**PROGRAMMING/USER FEATURES**

Programming via Internet Browser using a laptop, tablet or smartphone  
 DKS Video Calling app  
 All programming is shared in the cloud  
 Updates show as they occur

**CONNECTIVITY NETWORK CONNECTION**

User provided Internet connection required  
 Standard Residential Package Registration is required

**CONNECTIVITY CELLULAR CONNECTION**

Cellular connection available if Internet connection is not possible. Additional cellular connection fee applies.

**FEATURES**

- Cloud Based system
- Built-in IP Camera for Video Calling
- Broadcast Calling (up to four numbers simultaneously)
- 10 Residents, maximum of four (4) phone numbers per resident
- Entry codes can be set to either four (4) or five (5) digits
- Do Not Call schedule
- Hold Open schedule for each relay
- Entry Code schedule
- Relay (Door/Gate) Status: Closed – Open – Held Open
- Each relay (Entry Point) can be named
- Independent relay strike times
- Relay (Door/Gate) control: Close – Open – Hold Open

**ELECTRICAL/MECHANICAL**

- 16VAC, 20 VA transformer provided
- 12VDC Backup power input
- Three (3) Form C relays, 1A max
- Back Lighted Metal Keypad
- Back Lighted Metal Push to Call button
- Stainless Steel Faceplate
- Galvanized Steel sub plate

**MISCELLANEOUS**

Environmental: 10°F to 145°F (-12°C to 62°C)  
 Shipping weight approximately 15 lb (7 kg)

FCC (US) DUF6VT-12874-OT-T  
 DOC (CAN) 1736 4528 A

**DoorKing®, Inc.**

Access Control Solutions since 1948



120 S. Glasgow Avenue,  
 Inglewood, California 90301 U.S.A.  
 Tel: 310-645-0023 FAX: 310-641-1586  
 www.doorking.com

© 2026 All Rights Reserved.  
 Product specifications may  
 change without notice. Rev. 7/26



**MEMBER:**



**DISTRIBUTED BY:**

