

1602 OCTAGON ARM EXTENSION KIT / REVERSE EDGE

DoorKing Part Numbers:

1602-303

Octagon Arm 3-ft Extension Kit

8080-315

15-ft Reverse Edge + Red/Green LED
(Sold Separately)

This kit is designed for a **1602** barrier gate operator **ONLY**. It **CANNOT** be used with 1601 barrier **OR** 1603 auto-spikes barrier operators. It will extend a 14 ft octagonal arm an **extra three feet**. The reverse edge is sold separately but **highly recommended** for safety when lowering this very long arm.

Installation

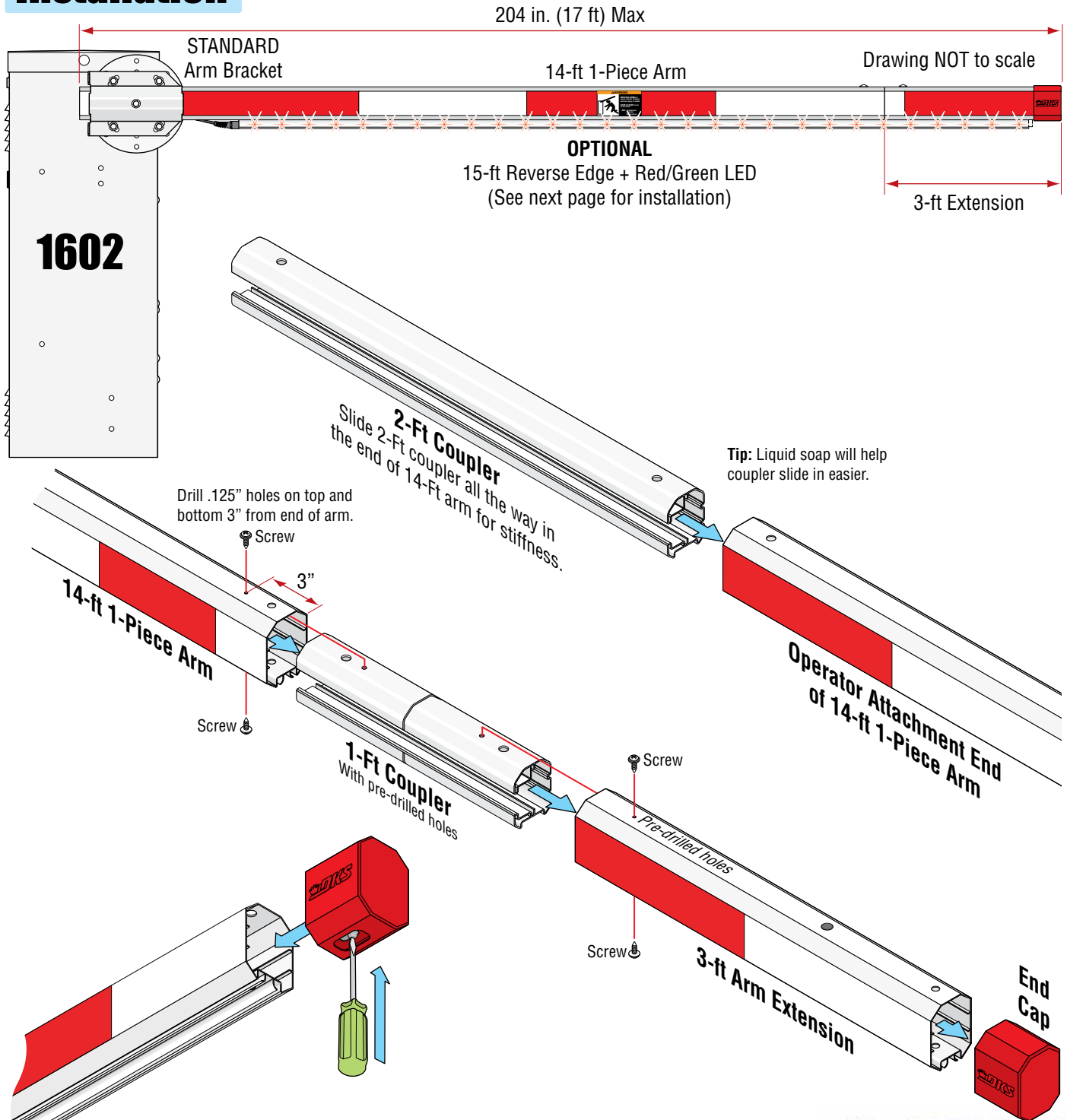

Install End Cap

Push a screwdriver through the hole in cap to release spring **while** pushing cap on. Keep pushing cap on until a "**CLICK**" is heard, locking it in place.

1601-805-C-2-24

Copyright 2024 DoorKing®, Inc. All rights reserved.

DKS
DOOR KING®
120 S. Glasgow Avenue
Inglewood, California 90301 U.S.A.

Installation of 15-Ft Reverse Edge

DoorKing Part Number:

8080-315

15-ft Reverse Edge + Red/Green LED
(Sold Separately)

This edge will **ONLY** fit on a 14-ft octagon arm with the 3-ft extension installed on it.

Note: DO NOT operate arm with a malfunctioning reverse edge.

Installation

Drawings NOT to scale

2 Slide on Stopper

Loosen set screws.



1 Remove End Cap

Push a screwdriver through hole in bottom of end cap to release spring while pulling cap off.

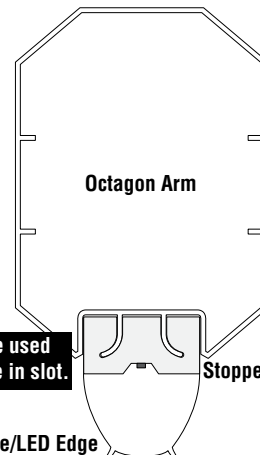

Stopper **MUST** be used or edge will slide in slot.

Stopper

Reverse/LED Edge

3 Slide on Edge

Tip: Liquid soap will help reverse edge slide on easier.

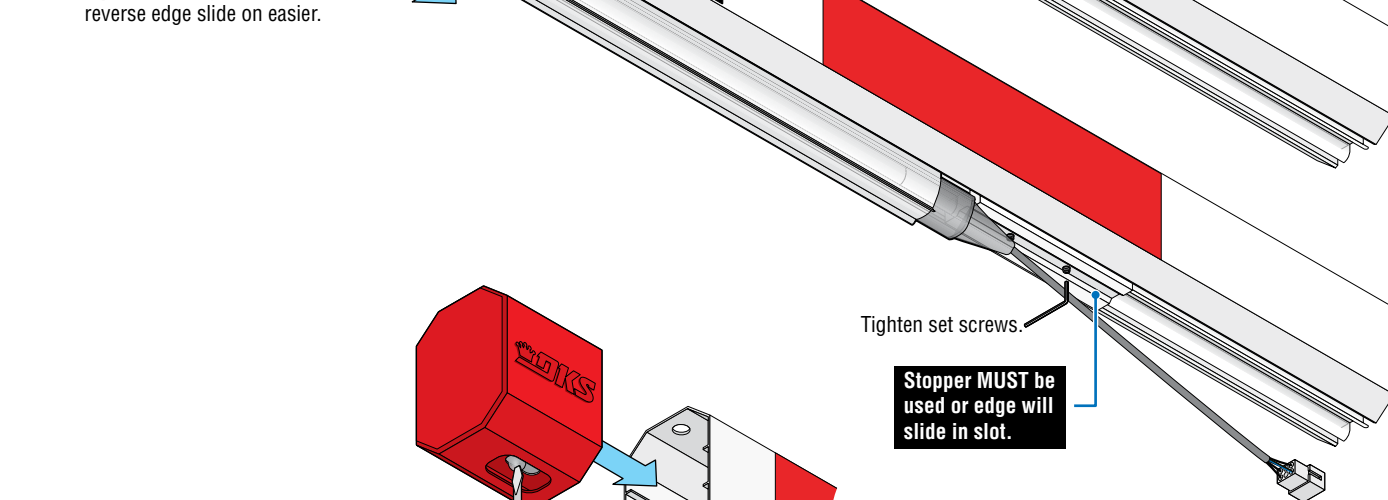

Reverse/LED Edge

Cover

Push stopper against reverse edge and tighten it so edge does **NOT** slide in slot.

Tighten set screws.

Stopper **MUST** be used or edge will slide in slot.

4 Reinstall End Cap

Push a screwdriver through the hole in cap to release spring while pushing cap on. Keep pushing cap on until a "CLICK" is heard which locks it in place.

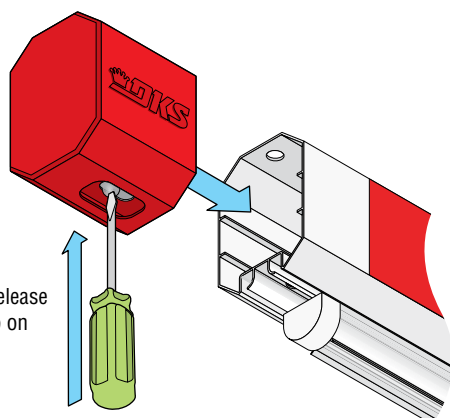

Plug connects to the 1601-356 wire harness (sold separately). see 1601-268 manual.