

3-PIECE OCTAGON ARM WITH LED/REVERSE EDGE KIT INSTALL

These LED/Reverse Edge kits are designed **ONLY** for the 1602 model barrier gate operator.

IMPORTANT NOTE: Installation of arms without LED/Reverse Edge kit see pages 7-9.

DoorKing Part Numbers:

1602-282

20 ft Arm Only

AND

1602-292

20 ft LED/Reverse Edge Kit
(Optional for 1602-282 Arm)

1602-284

24 ft Arm Only

AND

1602-294

24 ft LED/Reverse Edge Kit
(Optional for 1602-284 Arm)

1602-287

27 ft Arm Only

AND

1602-297

27 ft LED/Reverse Edge Kit
(Optional for 1602-287 Arm)

Overview of Installation

Prior to beginning the installation of the 3-piece arms **WITH** LED/Reverse edge kit, see pages 1-6. We suggest that you become familiar with the instructions, illustrations, and wiring guide-lines on these pages.

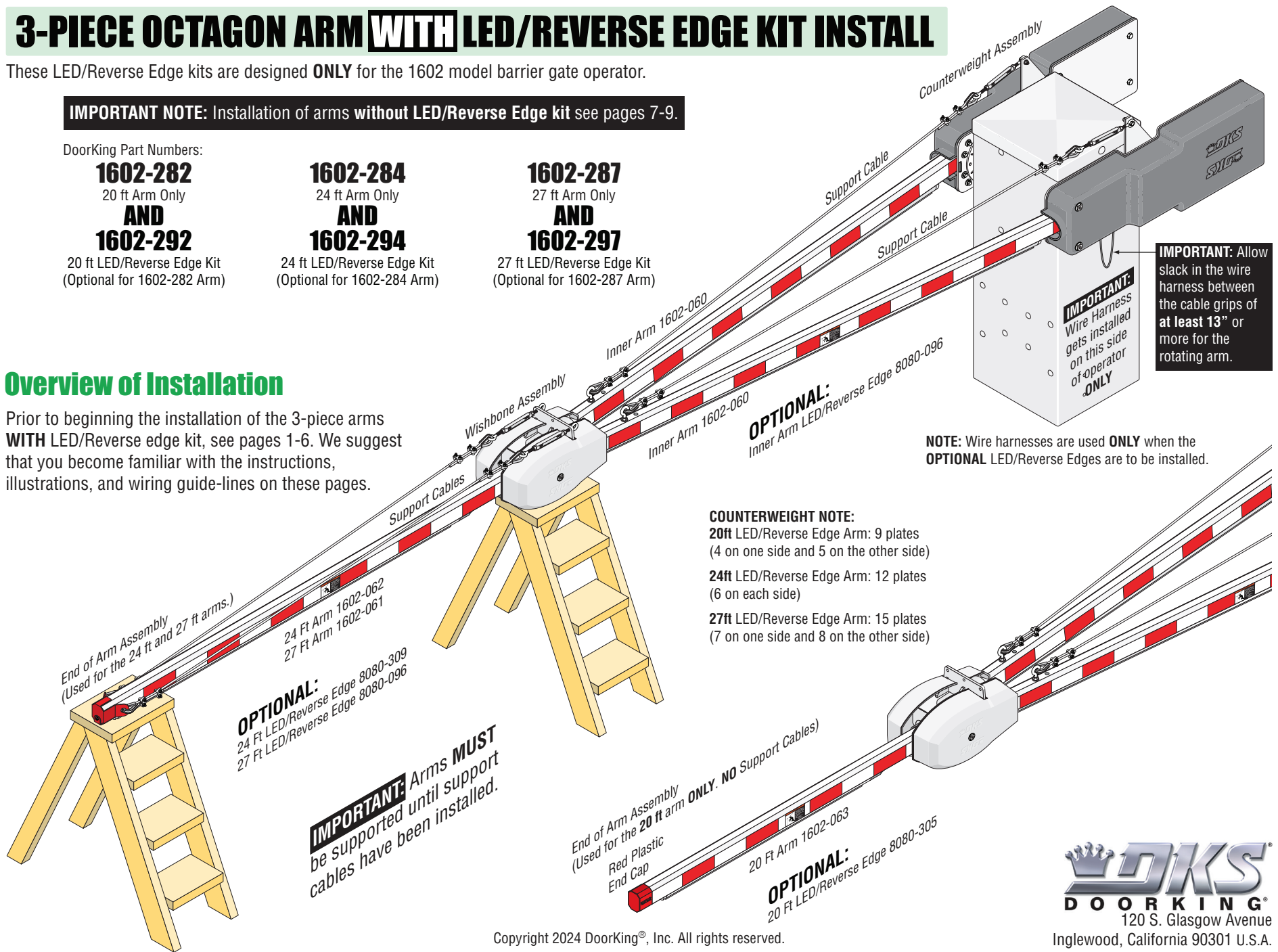

Copyright 2024 DoorKing®, Inc. All rights reserved.

Counterweight Assembly

Mount hubs on operator **FIRST** Test hubs **UP** and **DOWN** positions **BEFORE** installing counterweight mounting plates, then assemble arms, cables and wire harness on LED/Reverse Edge models.

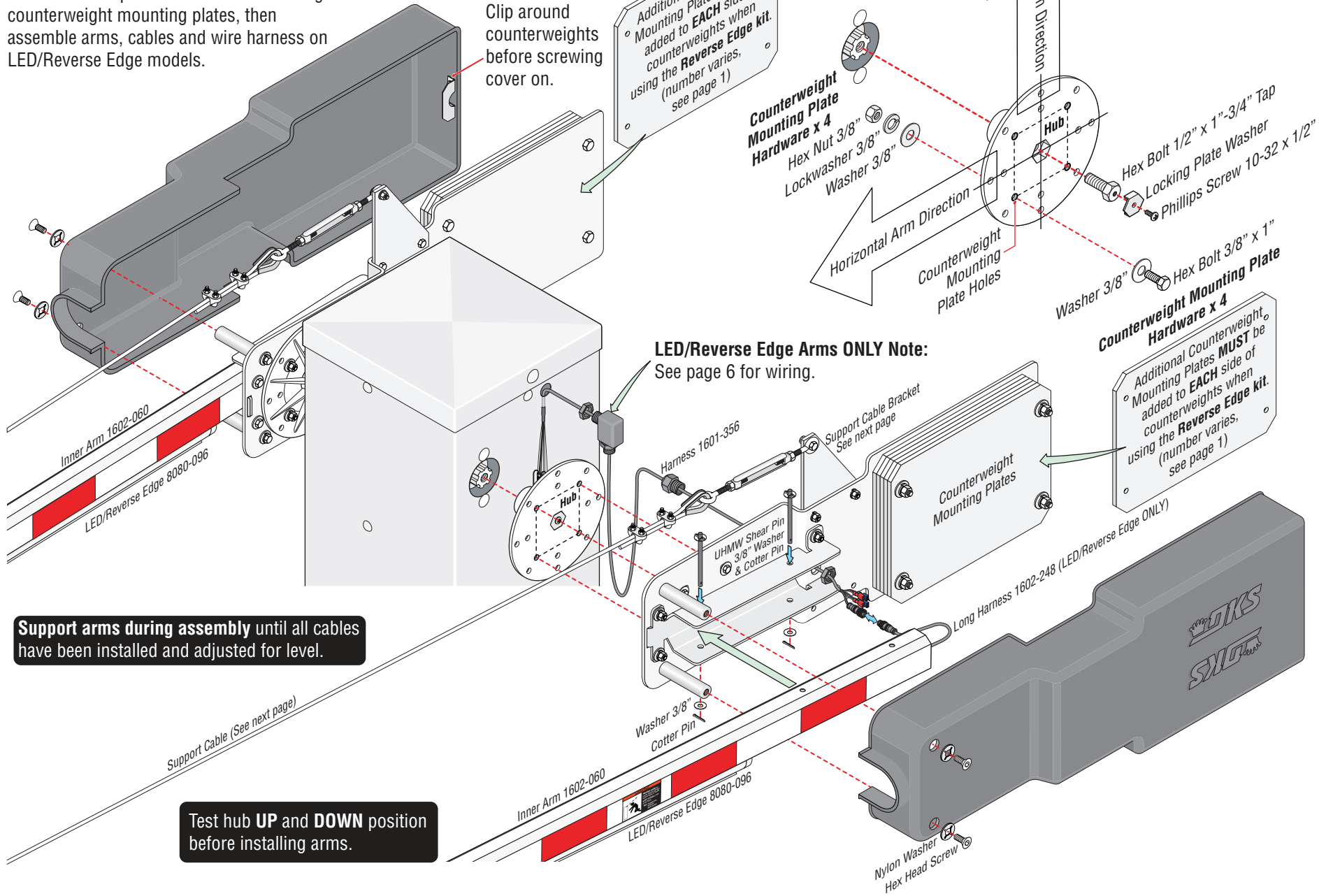

Clip around counterweights before screwing cover on.

Additional Counterweight Mounting Plates **MUST** be added to **EACH** side of counterweights when using the **Reverse Edge kit**. (number varies, see page 1)

Mounting Hub

Counterweight Mounting Plate Hardware x 4
Hex Nut 3/8"
Lockwasher 3/8"
Washer 3/8"

Hex Bolt 1/2" x 1"-3/4" Tap
Locking Plate Washer
Phillips Screw 10-32 x 1/2"

Washer 3/8" Hex Bolt 3/8" x 1"
Counterweight Mounting Plate Hardware x 4

Additional Counterweight Mounting Plates **MUST** be added to **EACH** side of counterweights when using the **Reverse Edge kit**. (number varies, see page 1)

LED/Reverse Edge Arms ONLY Note:
See page 6 for wiring.

Support arms during assembly until all cables have been installed and adjusted for level.

Test hub UP and DOWN position before installing arms.

Support Cable Bracket Installation

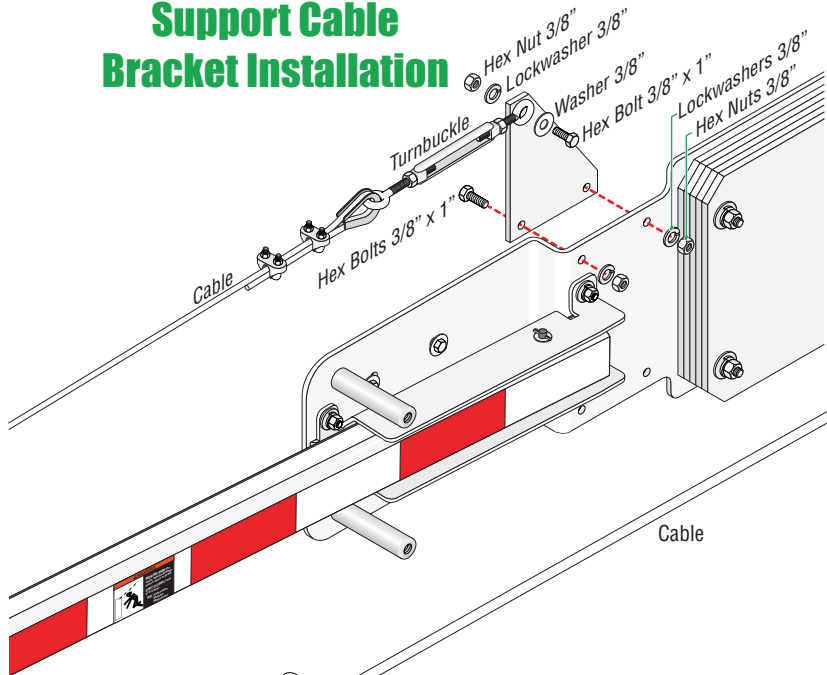

Typical Support Cable Installation

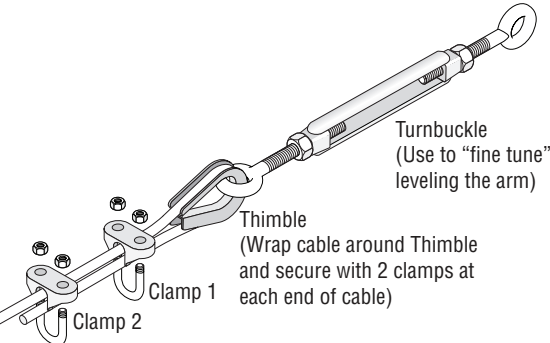

Inner Arms Assembly (Wishbone End)

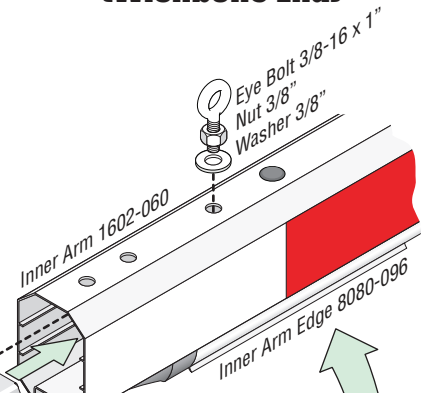

Attaching Turnbuckles to Wishbone 24 & 27 ft arms ONLY.

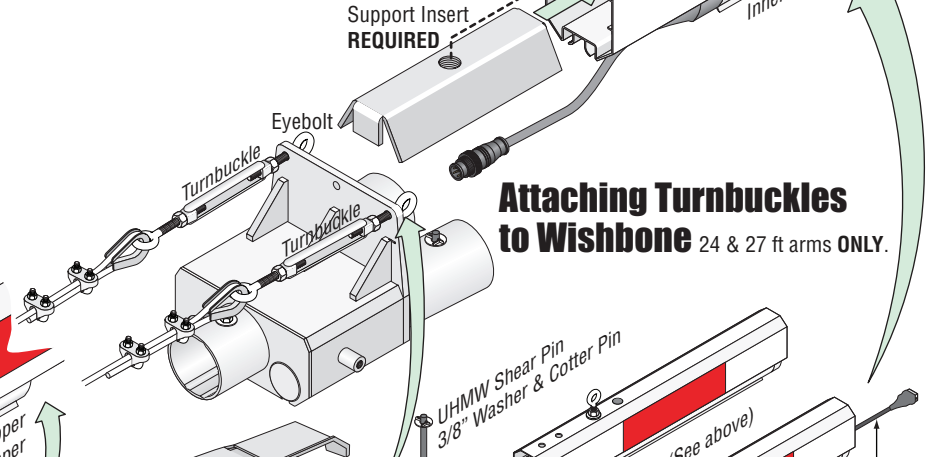

End of Arm Assembly

NOT used for the 20 ft arm.

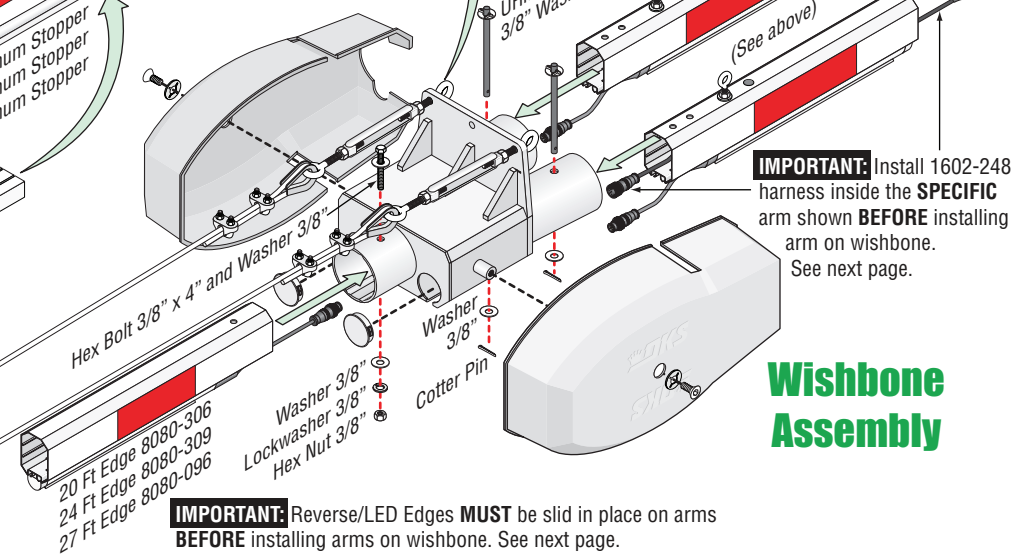
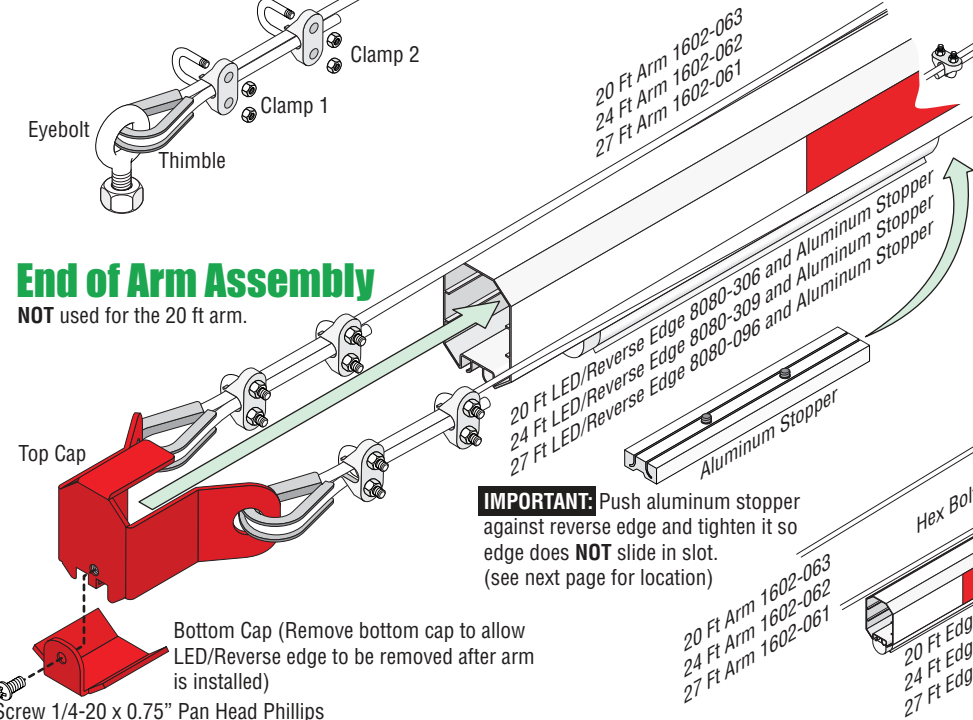

Wishbone Assembly

IMPORTANT: Reverse/LED Edges **MUST** be slid in place on arms BEFORE installing arms on wishbone. See next page.

LED/Reverse Edge Wiring

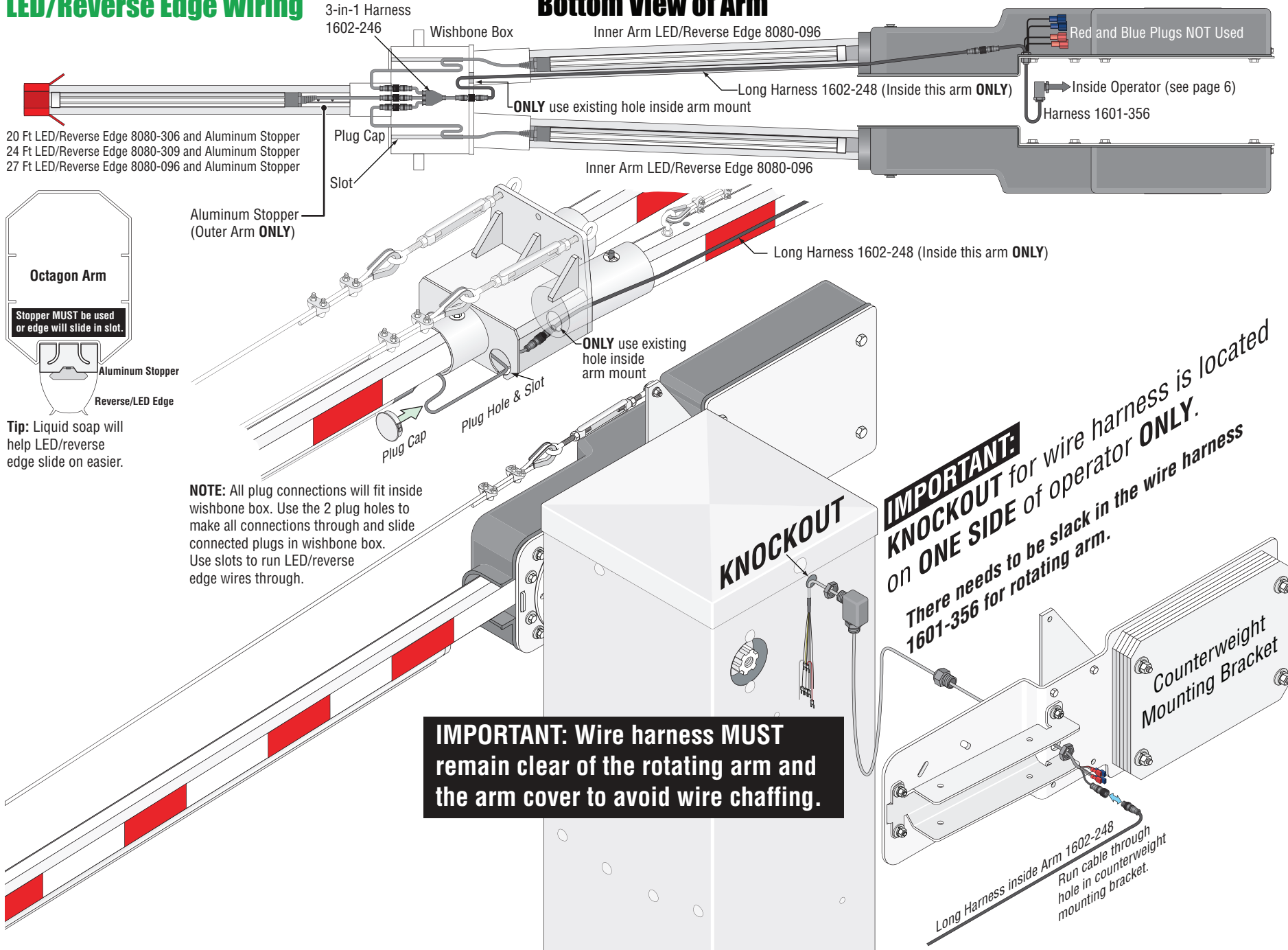

Bottom View of Arm

20 Ft LED/Reverse Edge 8080-306 and Aluminum Stopper
 24 Ft LED/Reverse Edge 8080-309 and Aluminum Stopper
 27 Ft LED/Reverse Edge 8080-096 and Aluminum Stopper

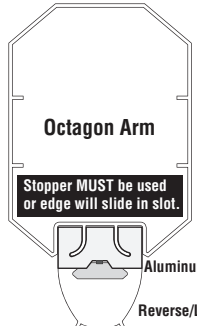

Tip: Liquid soap will help LED/reverse edge slide on easier.

Aluminum Stopper (Outer Arm ONLY)

NOTE: All plug connections will fit inside wishbone box. Use the 2 plug holes to make all connections through and slide connected plugs in wishbone box. Use slots to run LED/reverse edge wires through.

IMPORTANT: Wire harness MUST remain clear of the rotating arm and the arm cover to avoid wire chaffing.

IMPORTANT: KNOCKOUT for wire harness is located on ONE SIDE of operator ONLY. There needs to be slack in the wire harness 1601-356 for rotating arm.

Long Harness inside Arm 1602-248
 Run cable through hole in counterweight mounting bracket.

Mount Power Supply

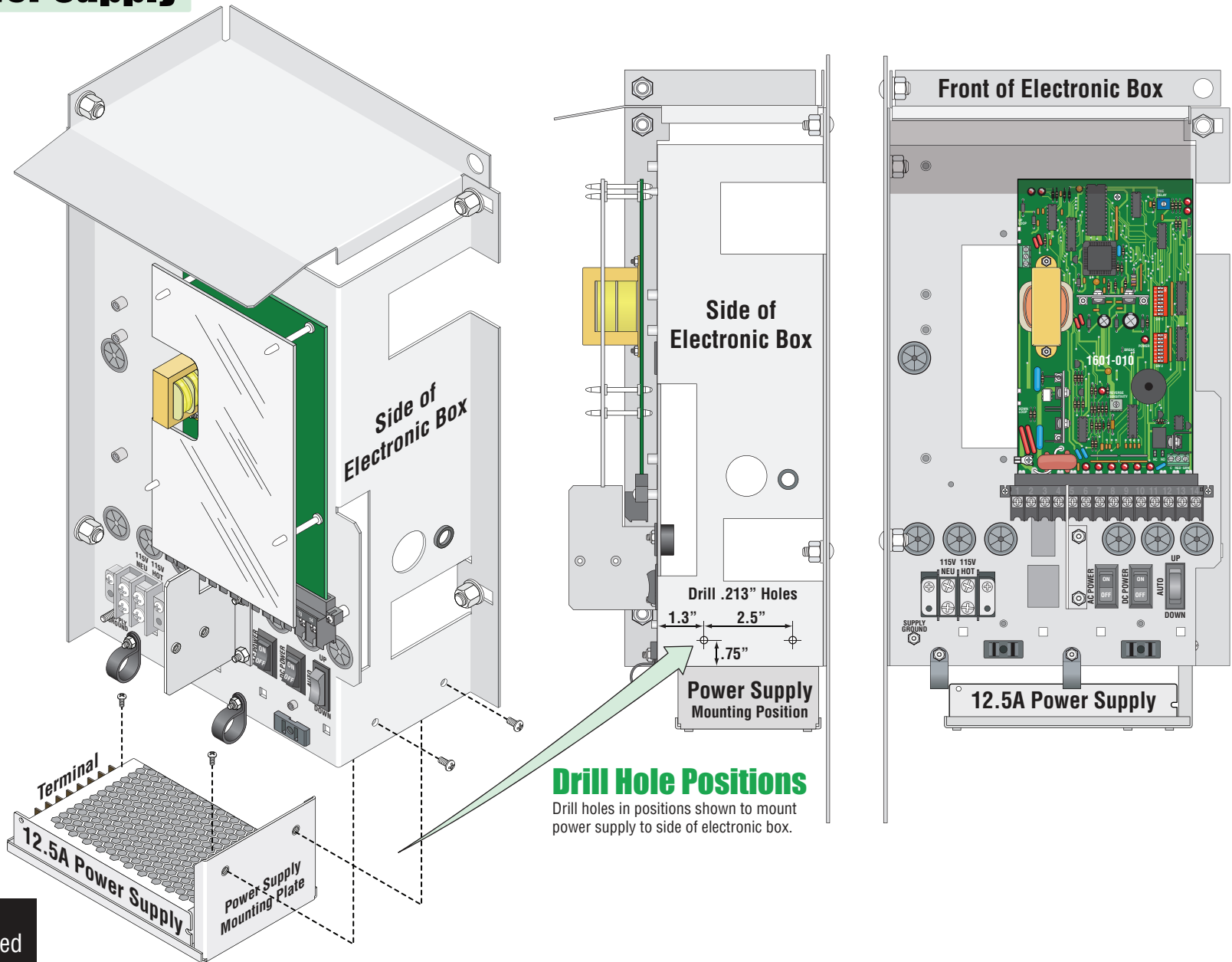

IMPORTANT: Power supply **MUST** be wired **BEFORE** mounting it as shown. See next page.

Mount Power Supply

Drill Hole Positions

Drill holes in positions shown to mount power supply to side of electronic box.

Wiring

MAKE SURE ALL POWER IS TURNED OFF TO OPERATOR!

Make sure ANY unused wires are properly terminated and do NOT have exposed bare wires or metal connectors that could cause the operator to malfunction.

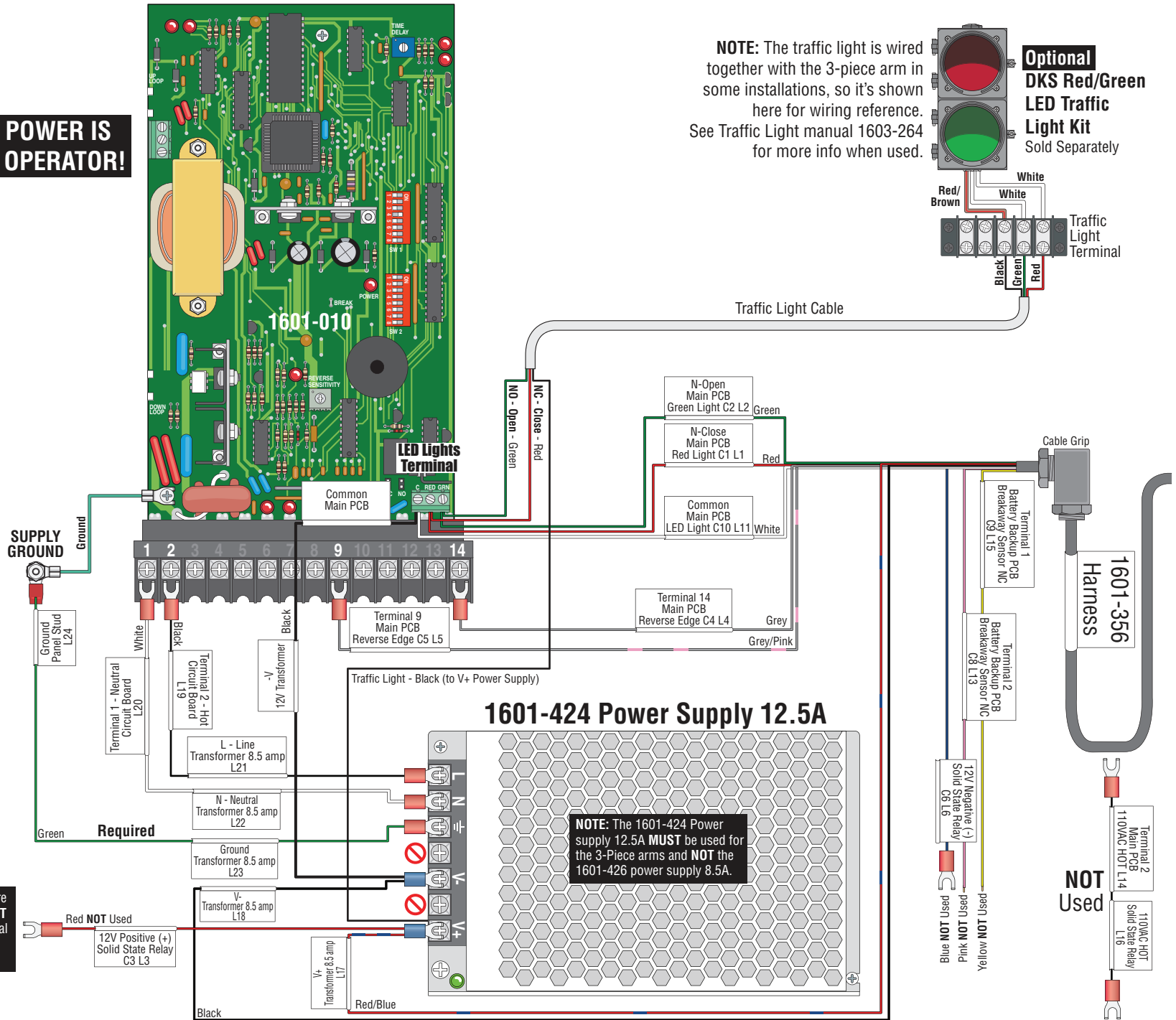

NOTE: The traffic light is wired together with the 3-piece arm in some installations, so it's shown here for wiring reference. See Traffic Light manual 1603-264 for more info when used.

Optional
DKS Red/Green LED Traffic Light Kit
 Sold Separately

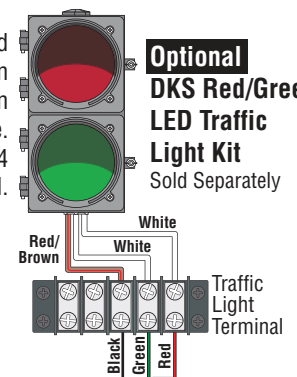

3-PIECE OCTAGON ARM ONLY INSTALL

These 3-Piece Arm ONLY are designed **ONLY** for the 1602 model barrier gate operator.

IMPORTANT NOTE: Installation of arms WITH LED/Reverse Edge kit see pages 1-6.

DoorKing Part Numbers:

1602-282

20 ft Arm Only

1602-284

24 ft Arm Only

1602-287

27 ft Arm Only

Overview of Installation

Prior to beginning the installation of the 3-piece arms **ONLY**, see pages 7-9. We suggest that you become familiar with the instructions, illustrations on these pages.

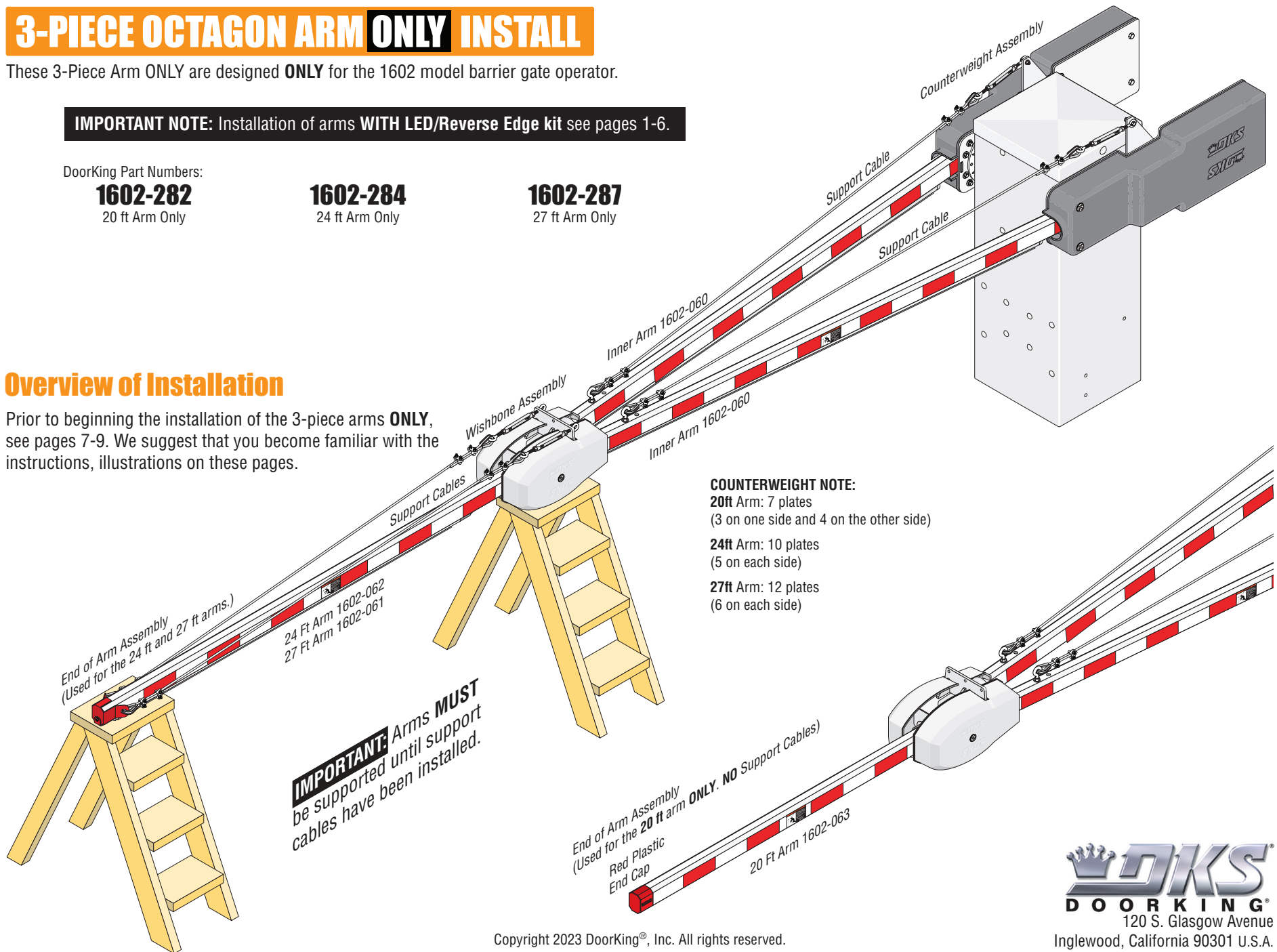

COUNTERWEIGHT NOTE:

- 20ft Arm:** 7 plates
(3 on one side and 4 on the other side)
- 24ft Arm:** 10 plates
(5 on each side)
- 27ft Arm:** 12 plates
(6 on each side)

Copyright 2023 DoorKing®, Inc. All rights reserved.

DOOR KING®
120 S. Glasgow Avenue
Inglewood, California 90301 U.S.A.

Counterweight Assembly

Mount hubs on operator **FIRST** Test hubs **UP** and **DOWN** positions **BEFORE** installing counterweight mounting plates, then assemble arms.

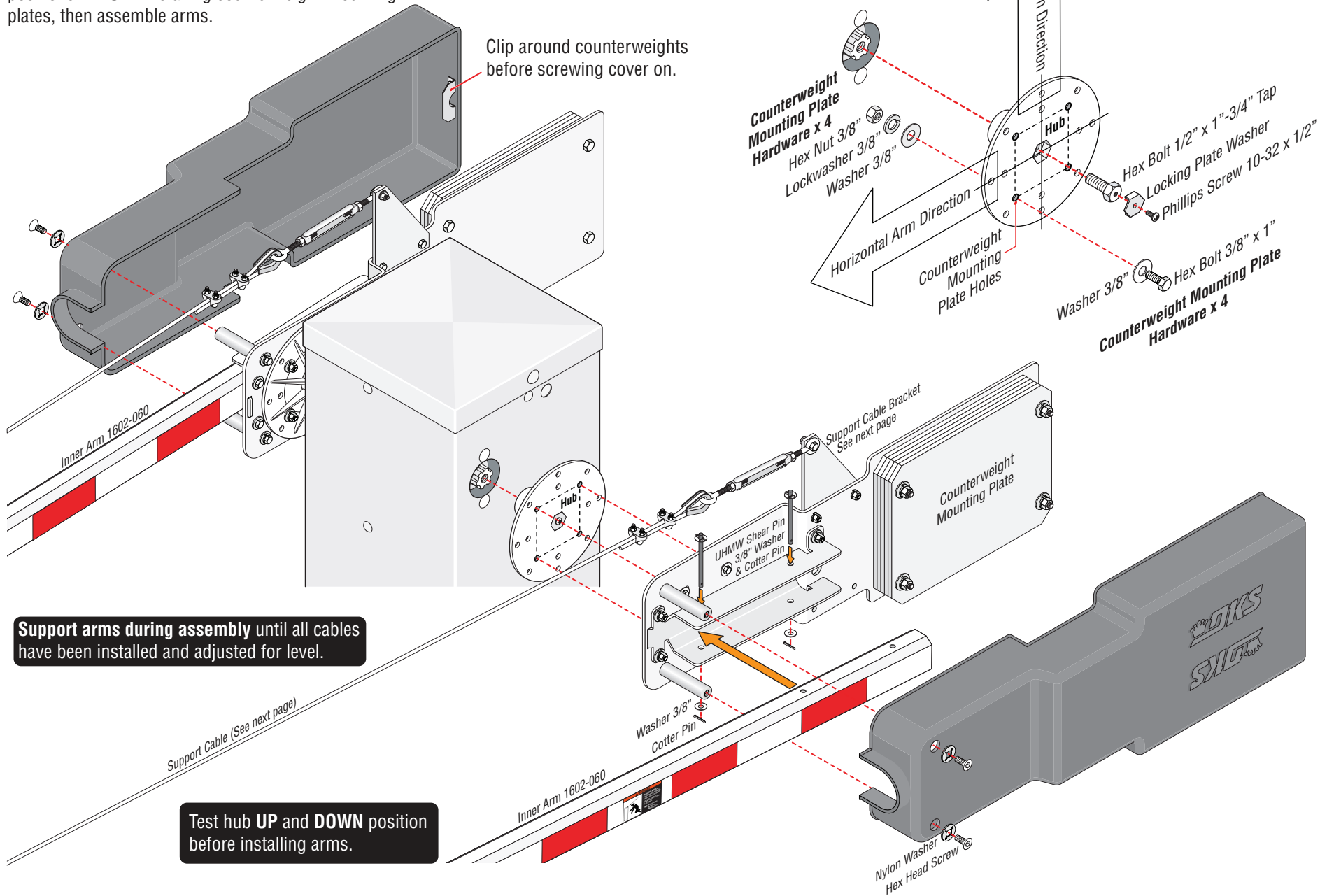

Support Cable Bracket Installation

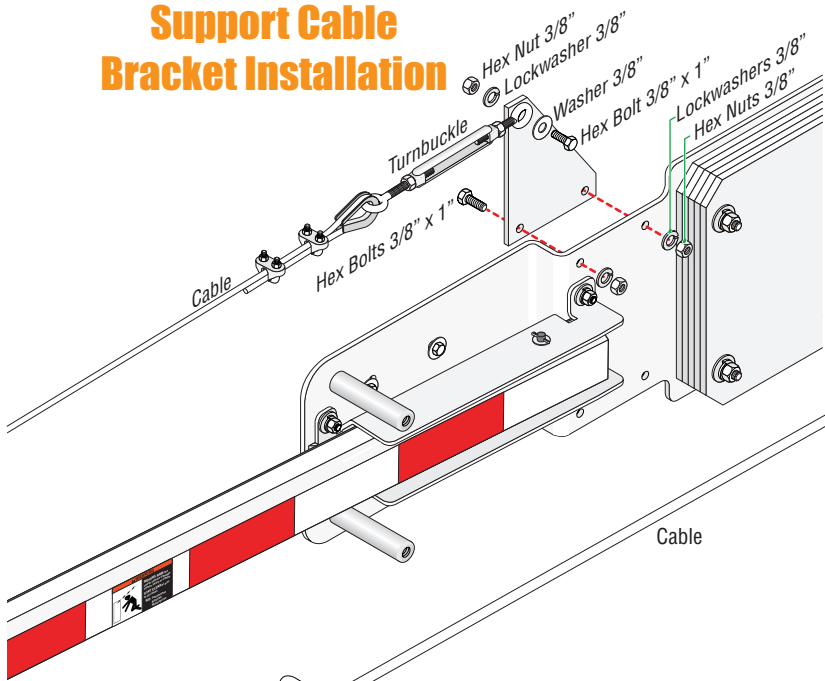

Typical Support Cable Installation

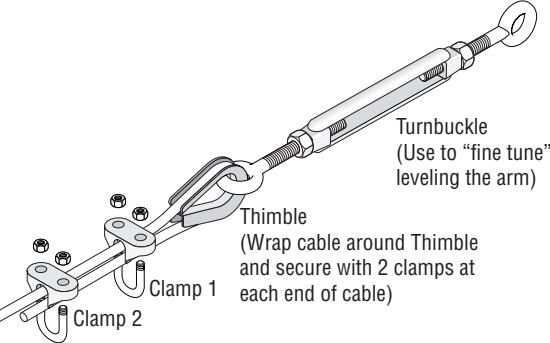

Inner Arms Assembly (Wishbone End)

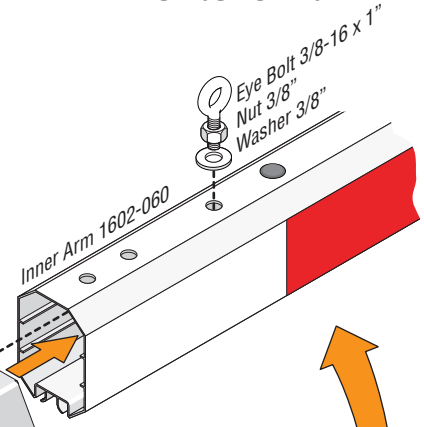

Attaching Turnbuckles to Wishbone 24 & 27 ft arms ONLY.

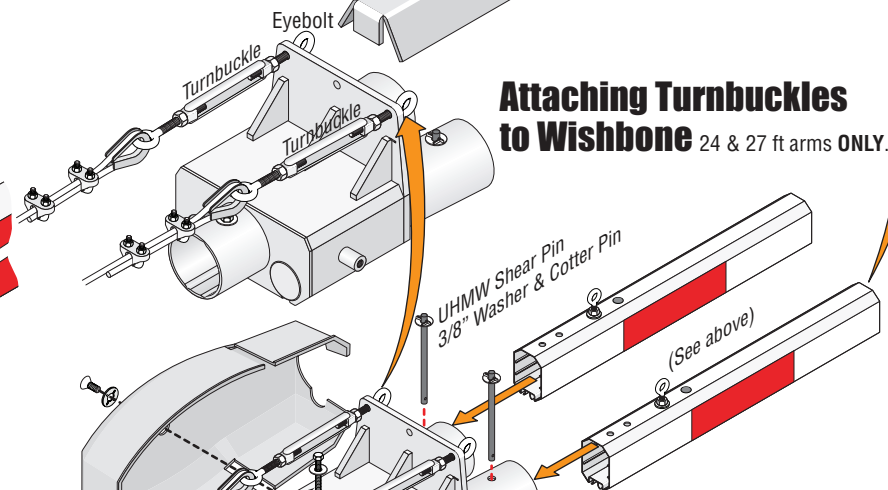

End of Arm Assembly

NOT used for the 20 ft arm.

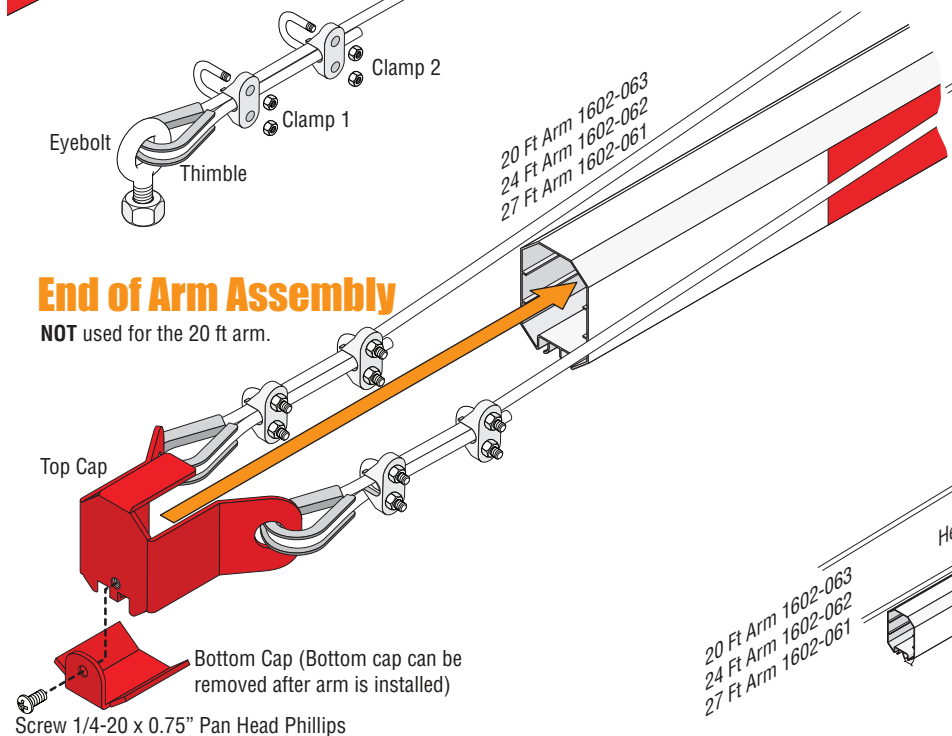

20 Ft Arm 1602-063
24 Ft Arm 1602-062
27 Ft Arm 1602-061

Wishbone Assembly

