



## System Layout Guidelines for 900MHz wireless tracker systems

**How the 900MHz system works:** This system works on a “One to Many” configuration, with a single “Base Station” providing connection to multiple “Remote Access Points” using a 900MHz wireless network.

The intelligence built into the DKS Wireless modules will transmit the signal from a Tracker Board back to the 1830 Controller using this wireless network. When a new card read is generated at the access device, the system looks to see if there are any ongoing transmissions. When the network path is clear, it will send the access request to the controller.

When “Wireless Trackers” are connected directly to the “Base Station” the system functions well, with little concern for Traffic on the Wireless Network or Hold Open periods. However, when one or more trackers are routed through a Repeater, there is an additional delay in transmission time to the Base Station. In high traffic applications, this may lead to occasional “collisions” in the wireless network. This could result in a card read not reaching the base station, meaning you may need to present the card a 2<sup>nd</sup> time to grant access.

### Take into consideration how the system will be used:

- ✓ **Card Access Activity:** How much activity will there be at the various access points throughout the property? How much activity will be at access points routing through a repeater?
- ✓ **Hold Open:** Which access points, if any, will be utilizing a Hold Open schedule?

**How many trackers can be connected wirelessly to an 1830 series controller?** The Base Station provides connection for Hard Wired trackers on Wiegand 1, or Wireless trackers on Wiegand 1. Wiegand 2 is always Wireless. **When connecting wirelessly you should use a limit of 8 Trackers per wiegand input.** In applications with very limited card access activity, you may add additional trackers using the “Zone Addressing” method, with a limit of 12 per wiegand input.

**What type of “Range” can you expect?** The system can provide extended connection ranges in many different environments. We have seen access devices located up to 2,000ft from the base station with acceptable signal strength. This is highly dependent upon the RF environment, physical parameters of the site, and antenna type & placement.

- ✓ **Using a range of 1,500ft with the long-range antennas should provide a typical working guideline.**
- ✓ **Using a range of 300ft with the “case mounted disk” antenna is a typical working guideline.**

**What is an acceptable Signal Strength at the access point tracker board?** The 900MHz system provides very reliable performance with relatively high amounts of signal loss. The scale is different on the 900MHz than it was on the 2.4GHz. Each measurable loss in signal is a smaller loss on the 900MHz than it was on the 2.4GHz. For example, a loss signal of 75 on the 900MHz is better than a loss of 75 on the old 2.4GHz system.

Each tracker remote, base station and repeater are capable of measuring for signal loss. The system will function with a loss of up to 85db. However, even 80 is a good signal. To provide sufficient overhead for reliable operation, you should be shooting for a **signal loss in the mid 70's or lower** (target 74-76 or lower)

**What should be considered when adding repeaters?** The system works best when all tracker remotes are connecting directly to the base station. A repeater can be added, when necessary, for a few access points that are extreme distances from the base station, or are getting too much signal loss.

**How many trackers can run through a repeater?** Again, this is dependent upon the amount of activity, and how many readers are going direct to the base station. The general guideline should be a limit of 2-4 Trackers routing through a repeater. In high activity applications 2 trackers through the repeater, in low activity applications 4 trackers through the repeater.

**Can you route a tracker through 2 repeaters?** Try to avoid this set up. In most applications, you should only route a tracker remote through a single repeater. If you try to cascade through multiple repeaters between the tracker location and the base station, there is a higher chance of "wireless collisions" which result in the access request not reaching the base station. This problem is more significant with installations where there is a high amount of card access activity. We recommend routing through multiple repeaters only in very low activity applications.

**Repeater Settings, Channel and Network ID?** You must separate Channels and Network ID's by at least 2 settings in the repeater. For example, if BASE is on Channel 1, then the Remote Channel of the Repeater has to be CH 3 or higher, and Network ID's must be unique for different signal path.

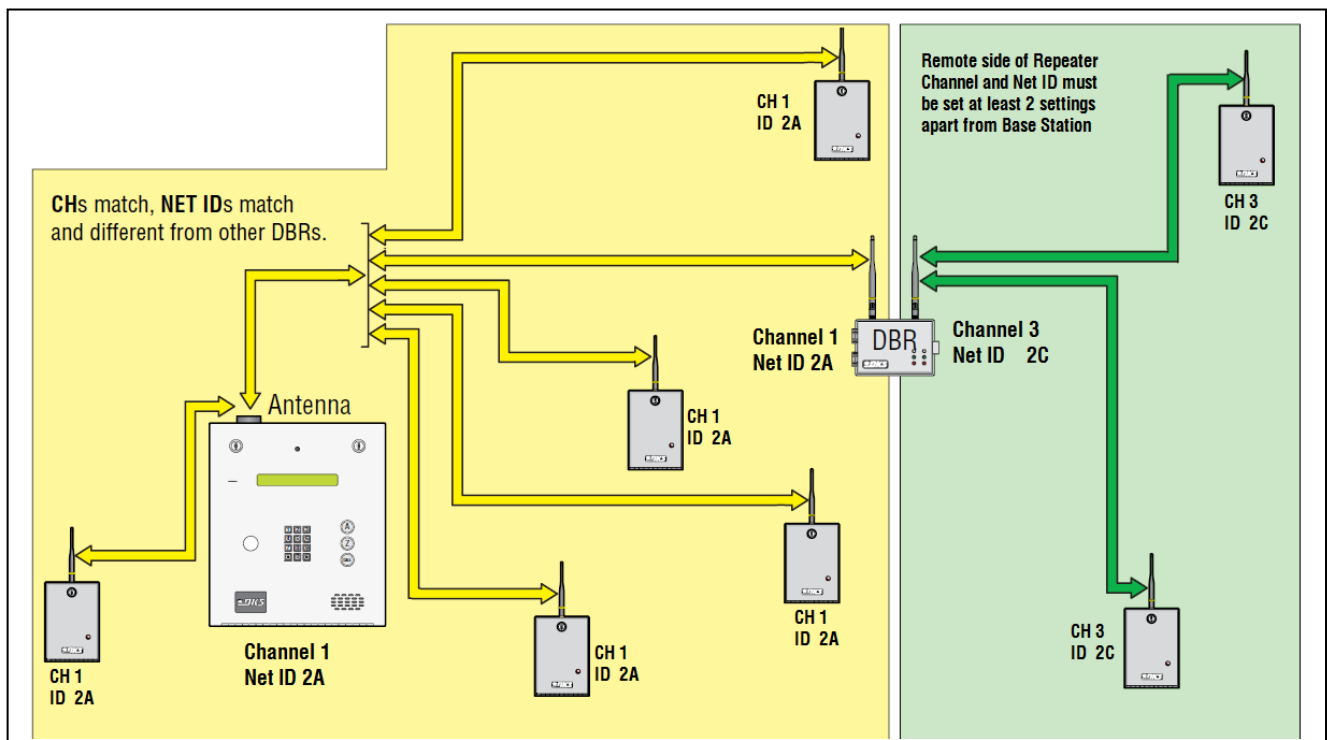

**How does Hold Open affect the wireless network?** Each Tracker board will check in periodically with the 1830 controller to see if a Hold Open schedule is active. By default, trackers check in every 5 minutes. In systems with multiple trackers, each tracker is delayed slightly by tracker address to avoid having them all check in at the same time.

On Wireless systems this adds to traffic on the wireless network. There is a programming step that can change the timing for trackers to check in. By default, this is 5 minutes, but you can change this from 2min – 30 min.

If you have trackers that will **NEVER** be using a Hold Open schedule, you can set these to 30 min and reduce the traffic on the wireless network. Any access point that may potentially be using a Hold Open Schedule should be set to 5-10 min check in time. This depends upon how precise the customer wants the hold open schedule to be for that particular access point.

**Note, if trackers are going through a repeater, set at least 1 tracker on the repeater must be set to check in every 15 min.** This helps to keep the repeater active on the network. If this is not set properly, and there is no traffic for 20 minutes, the repeater will reboot, potentially missing a card read.

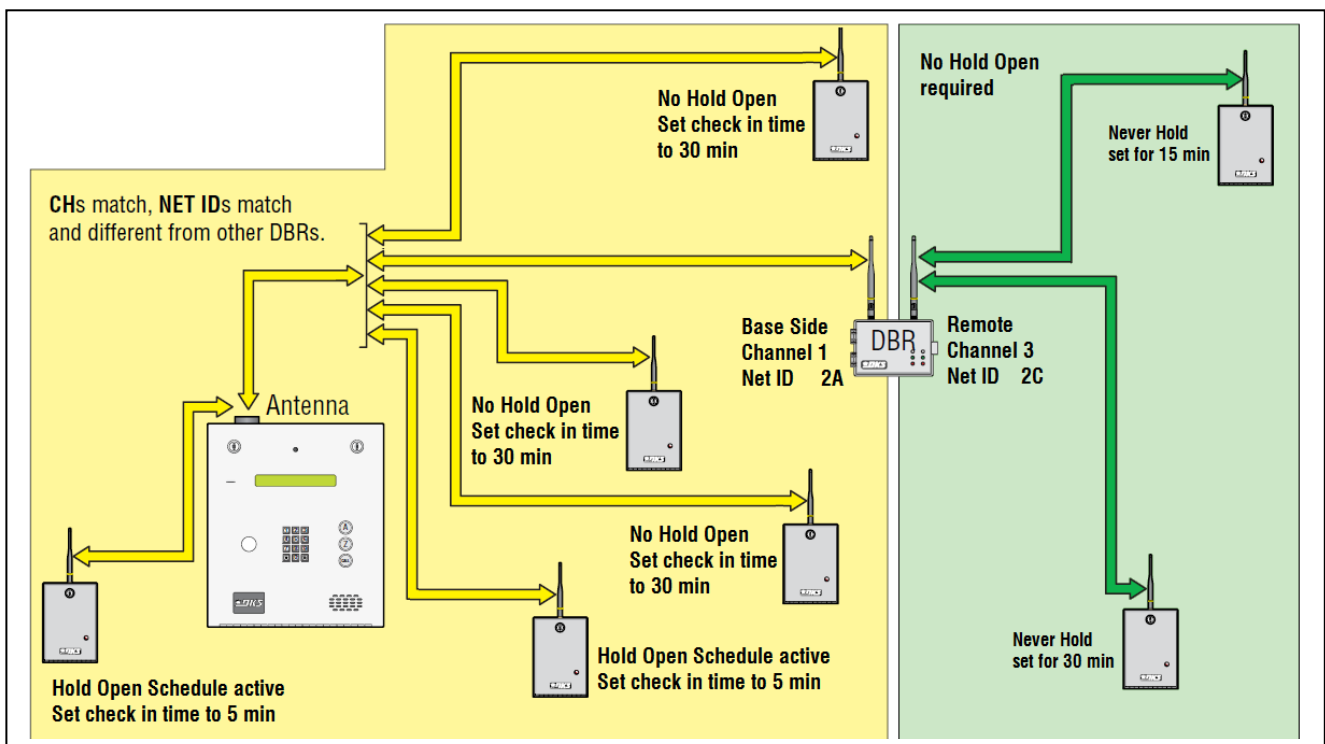

## Wireless Tracker Layout examples:

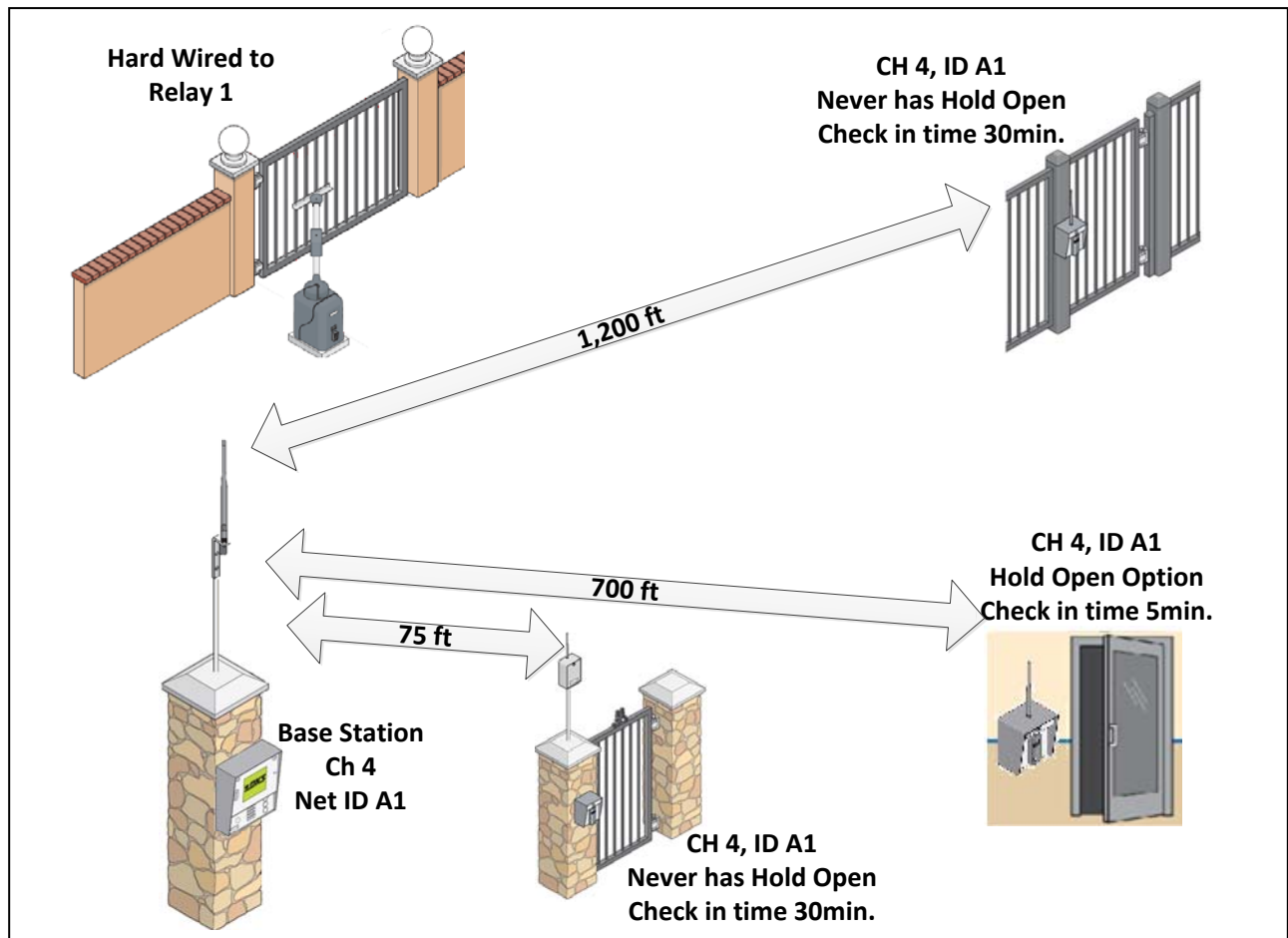

### Tracker Network Settings – Channel and Network ID.

- Channel selection is rotary switch with 16 settings
- Net ID is set of 2 rotary switches, with 255 settings.
- Separate channels by at least 2 settings when using repeaters
- Use different Net ID even if channels are different.

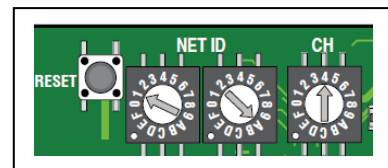

### Tracker Programming Step 17 – How often Tracker checks in for Hold Open activity.

- **Selectable from 2 – 30 minutes.** If an Access Point will never use a Hold Open schedule, setting these for longer periods between “checking in” will help reduce traffic on the wireless network.
- **When running through a Repeater, at least one tracker must be set at 15 minutes or lower to prevent the Repeater from re-booting during periods of no card activity.**

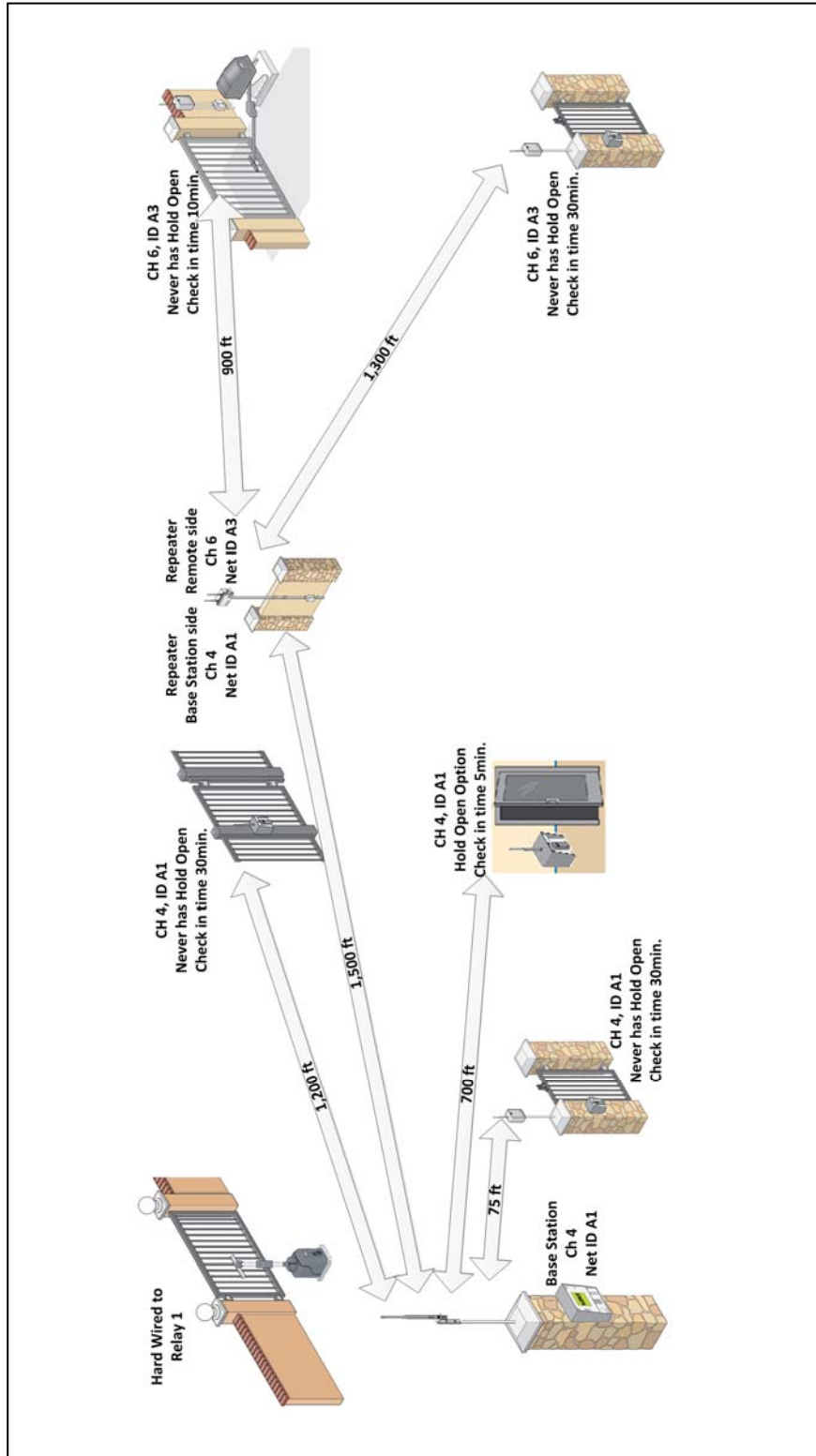

Please contact DoorKing Technical Support for more information on these changes.