

ILLUSTRATED PARTS BREAKDOWN - IPB

Bill of Materials - BOM

1835 Flush Mount
1835-084

Item	Part Number	Quantity	UM	Description
15	1814-003	1	EA	Cover Plastic Display
20	1804-023	1	EA	Decal FCC
30	1804-042	1	EA	Hole Plug
40	1400-009	1	EA	Decal Identification
42	1835-065	1	EA	Manual - Owner's
	1835-066	1	EA	Manual - User's
45	1804-039	2	EA	Retaining Strip Keypad
50	1895-016	1	EA	Keypad 10 Pin Alph/Num Header
51	1804-038	1	EA	Wire Ribbon Cable Assy 10 Cond
55	2599-008	1	EA	Label Patent
59	1998-010	1	EA	PCB Microphone Short, SMT
60	4001-035	2	EA	Lock N16058BDxSFx2K Key 16120
63	1702-501	2	EA	Cam 7/8"
70	2902-006	2	EA	Nut Nylon Lock 10-32
75	2902-002	4	EA	Nut Nylon Lock 4-40
80	2902-003	23	EA	Nut Nylon Lock 6-32
85	1814-101	1	EA	Box Phone Flush
90	1814-022	1	EA	Subplate Flush 3 Button
95	1814-054	1	EA	Faceplate Phone Flush 3 But
100	1814-032	1	EA	Plate - Switch 3 Button
101	2600-734	1	EA	Nameplate Plastic DKS Small
102	2802-040	2	EA	Washer Push on Clamp
103	1897-050	2	EA	Gasket Support Thick 1/16"
105	1835-010	1	EA	PCB Modem Prog/Electr Dir Phone
110	2905-001	2	EA	Screw Round Head 6-32 x 1/4"
115	2905-003	2	EA	Screw Round Head 6-32 x 1/2"
125	1804-016	6	EA	Screw Truss Head 6-32 x 3/16"
135	2900-905	4	EA	Standoff Aluminum 7/16" 6-32
140	3002-004	2	EA	Spacer Nylon 6 x 7/16"
145	1804-290	1	EA	Speaker Assembly
146	1860-032	4	EA	Washer Nylon Retaining #6
147	1860-126	4	EA	Washer Nylon Shoulder
155	1804-024	1	EA	Switch Micro No NC C
165	1814-049	1	EA	Terminal 20 Pin
170	1804-060	2	EA	Transformer 16.5 VAC 20VA plug
175	1800-018	2.91	FT	Weather Strip .125"x .187"
190	7082-059	1	EA	Wire 8.5" Green 18 AWG Strd
210	1804-040	1	EA	Wire Telephone Line Cord
215	1804-028	3	EA	Mount Wire Clip
230	1814-140	1	EA	Button Assembly Chrome A
231	1814-141	1	EA	Button Assembly Chrome Z
232	1814-142	1	EA	Button Assembly Chrome Call
235	1815-025	1	EA	Remote Program Pac Windows
240	3002-021	4	EA	Spacer Nylon 6 x 3/8"
245	2600-884	1	EA	Label E.T.L. Separable
255	1804-196	1	EA	Speaker Gasket 1/16" thick
260	1897-053	1	EA	Gasket, Microphone
265	1876-025	2	EA	Ferrite Snap-on Filter Steward
275	1835-147	1	EA	Memory 3000 Phone Card APB
276		1	EA	Wire Harness 1835 Front Panel

1835 Flush Mount - Enclosure

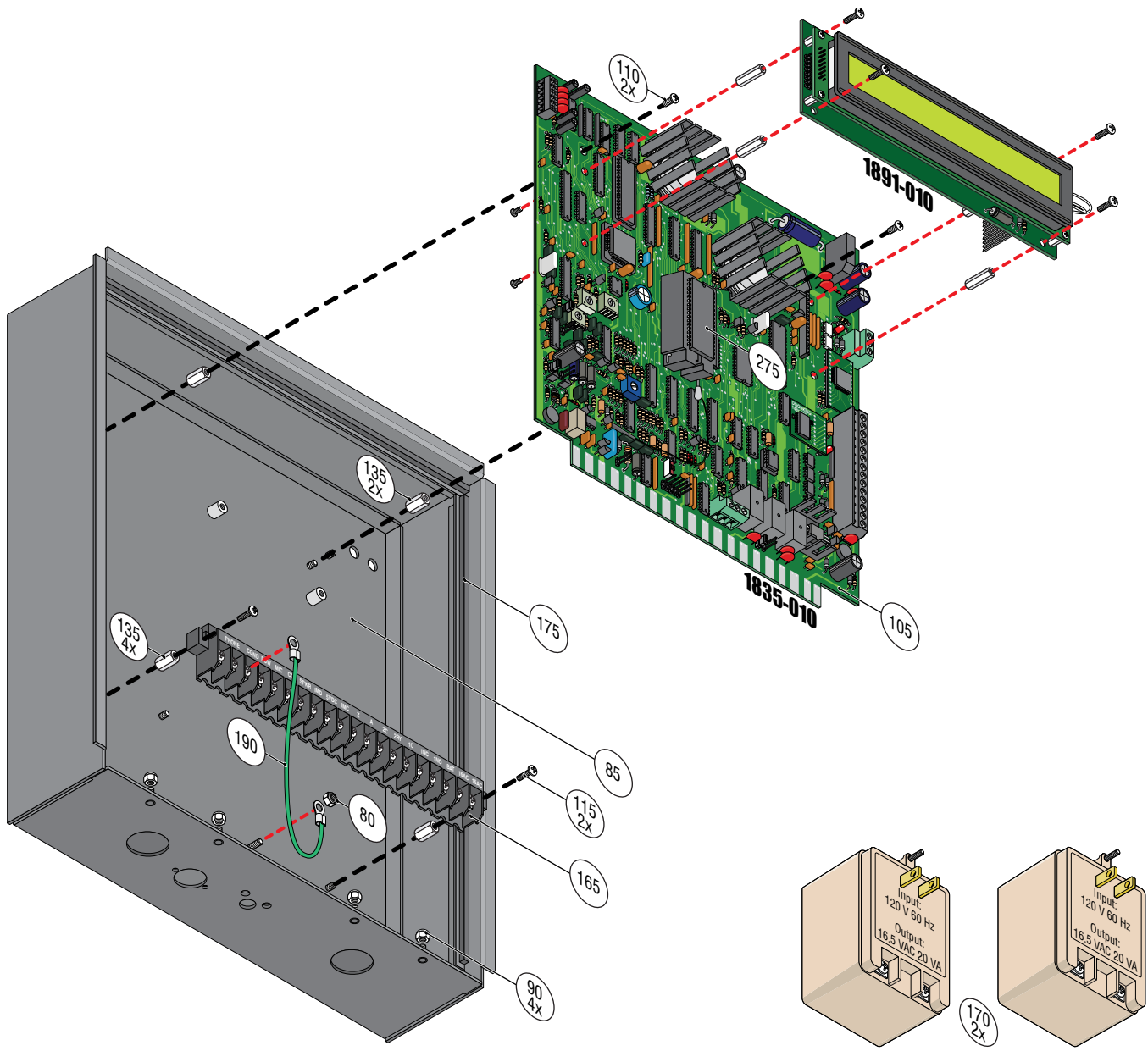

1835 Flush Mount - Faceplate

