

REVISIONS			
REV.	DESCRIPTION	DATE	APPROVED
B	Replaced 6500-453 + 6500-463 Covers w/6500-454 and 6500-464; 6500-307 Bracket was 6500-284	01/29/19	DC
C	Replace 4001-035 w/4001-055	06/10/20	SR
D	Update IPB completely: Removed drawing views of 6500-440 Cover, 6500-400 Hub Assy and 6500-430 Arm; 1400-022 1X was 2X; Added 2600-410 1X; 2600-731 1X was 2X; 2615-053 2X was 2615-052 2X; Added 2615-055 4X, 2615-153 3X and 2615-655 1X; 2616-001 8X was 2X; Added 2616-019 4X; 2616-062 2X was 2616-060 2X; 2620-019 4X was 8X; Added 2620-028 5X; 2620-047 6X was 4X; 2620-076 2X was 2620-075 1X; Added 2620-409 2X; 2620-411 13X was 3X; Added 2902-010 1X; 6500-118 1X replaced 6500-123 1X and 6500-148 1X; Added 6524-380IPB; Removed 6524-880IPB; 6600-035 2X replaced 6600-030&6600-032;	11/05/20	Tpham

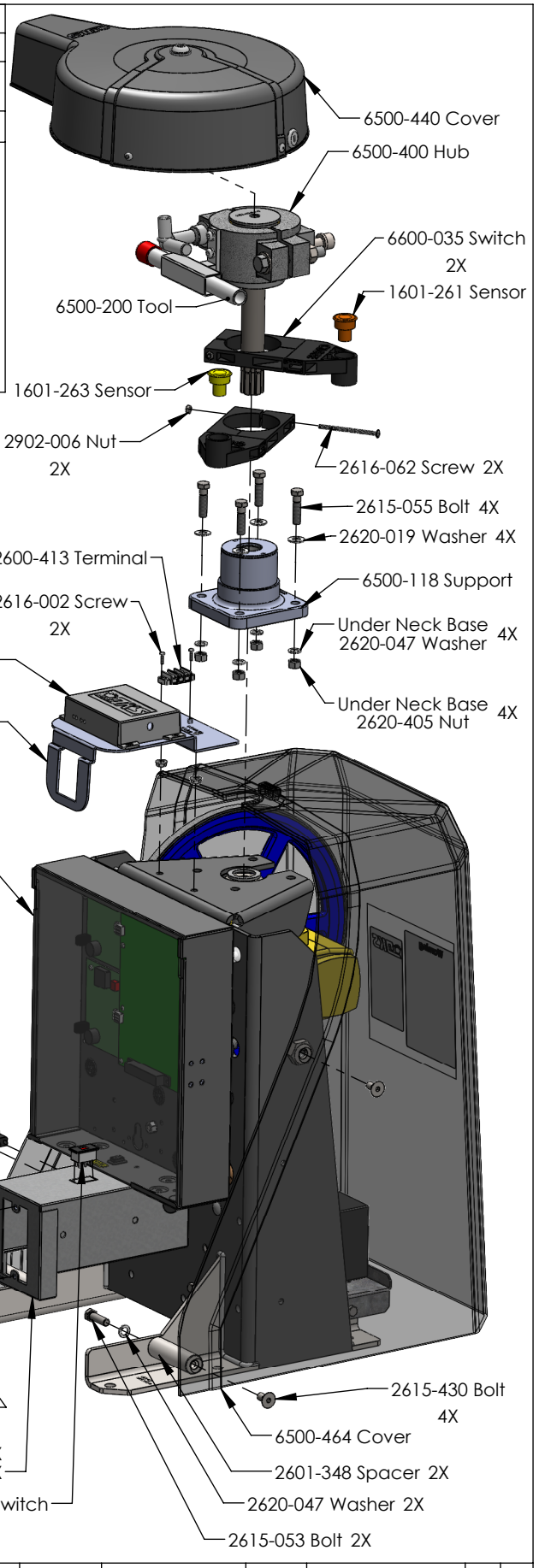

Front View IPB

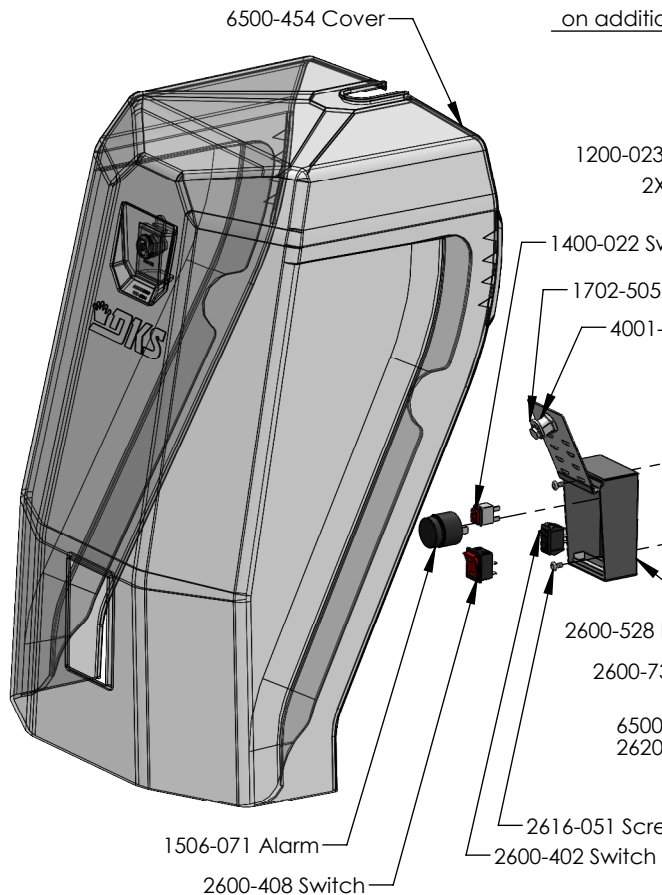

DRAWN	Tpham		DWG. NO.	6524-380	REV.	D
DATE	11/02/20		WHERE USED			
NAME	Swing Gate Operator DC Primary					
PROPRIETARY & CONFIDENTIAL: The information contained in this drawing is the sole property of DoorKing, Inc. Any reproduction in part or as a whole without written permission of DoorKing, Inc. is prohibited.						
DO NOT SCALE TO DRAWING	SHEET SIZE	A	SCALE:	1:50	SHEET 1 OF 4	

Back View IPB

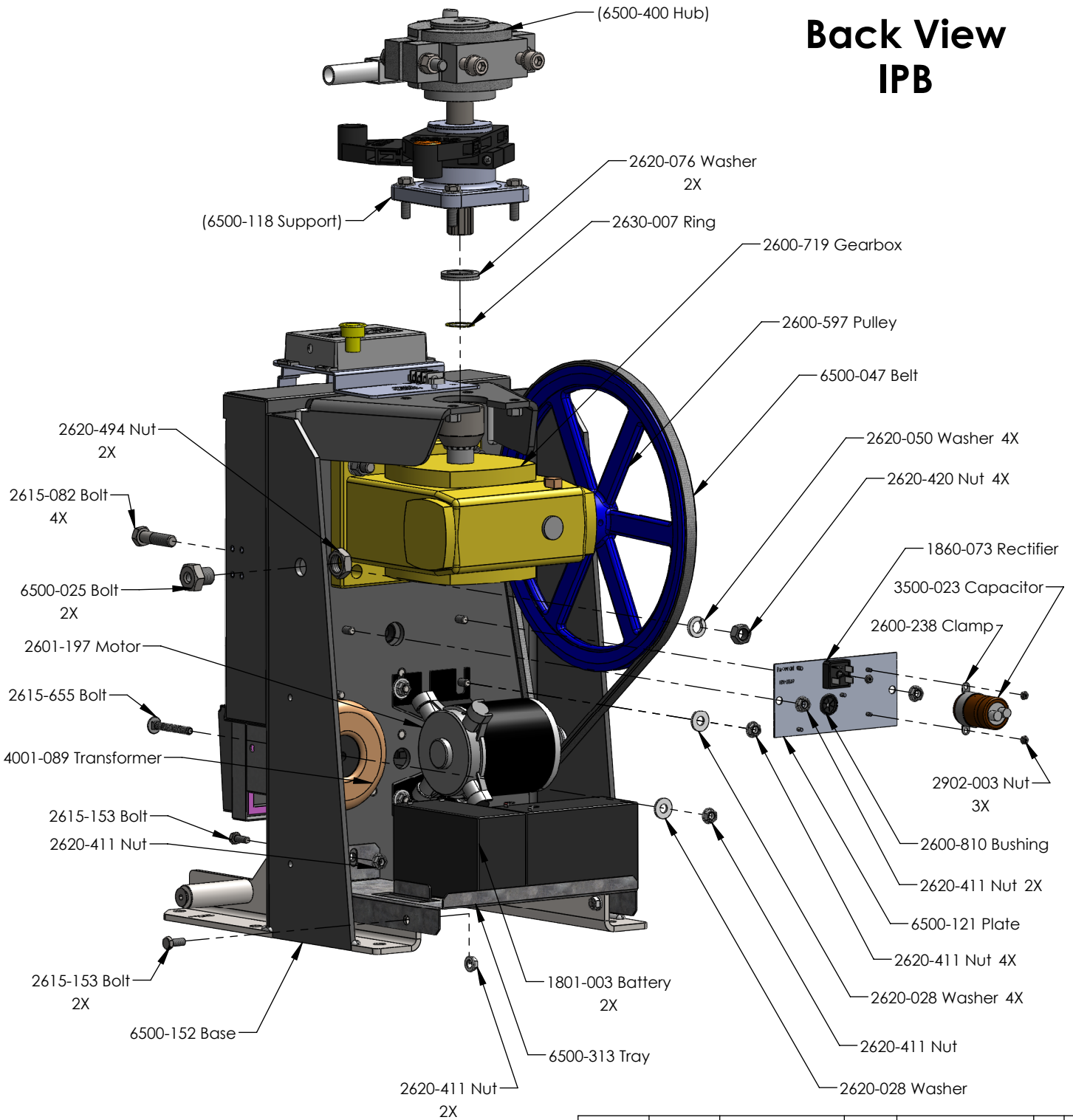

DRAWN	Tpham		DWG. NO.	6524-380	REV.	D
DATE	11/02/20		NAME	Swing Gate Operator DC Primary	WHERE USED	
<small>PROPRIETARY & CONFIDENTIAL: The information contained in this drawing is the sole property of DoorKing, Inc. Any reproduction in part or as a whole without written permission of DoorKing, Inc. is prohibited.</small>						
DO NOT SCALE TO DRAWING	SHEET SIZE	A	SCALE: 1:50	SHEET 2 OF 4		

PCB Enclosure IPB

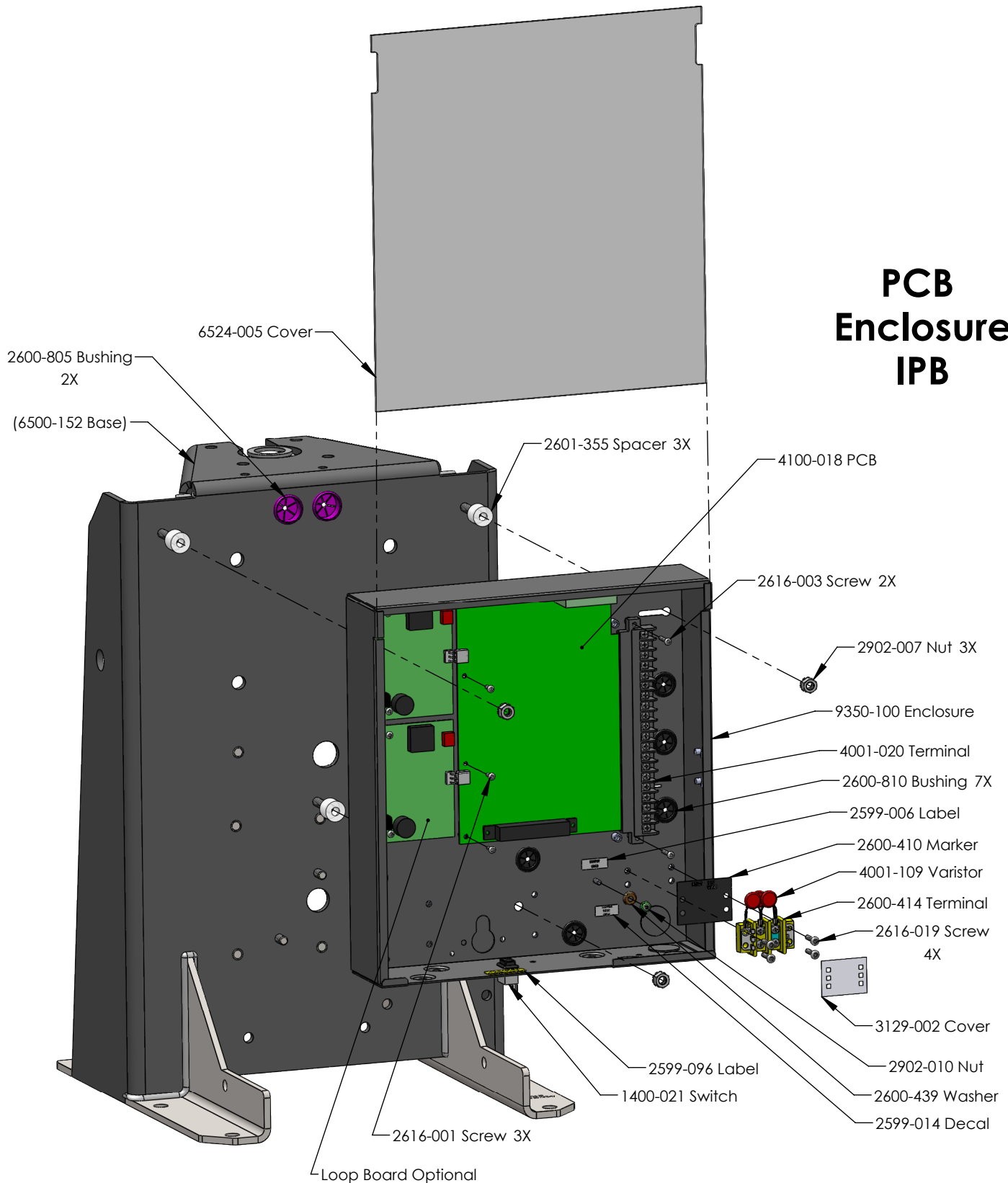

DRAWN	Tpham		DWG. NO.	6524-380	REV.	D
DATE	11/02/20		WHERE USED			
NAME	Swing Gate Operator DC Primary					
PROPRIETARY & CONFIDENTIAL: The information contained in this drawing is the sole property of DoorKing, Inc. Any reproduction in part or as a whole without written permission of DoorKing, Inc. is prohibited.						
DO NOT SCALE TO DRAWING	SHEET SIZE	A	SCALE: 1:50	SHEET 3 OF 4		

PartNo	Description	QTY.
1200-023	Outlet Snap-In Qualtek	2
1400-021	Momentary Rect Button Switch	1
1400-022	Switch Push Button SnapIn Red	1
1506-071	Tone Generator Alarm Loud	1
1601-261	Switch Mag Sensor Rec Orange	1
1601-263	Switch Mag Sensor Reces Yellow	1
1702-505	Cam 9/16"	1
1801-003	Battery 12V 7.2 AmpHour	2
1860-032	Washer Nylon Retaining #6 (not shown on drawing)	2
1860-073	Bridge Rectifier 35Amp	1
2344-037	Wire Harness 2 Position (not shown on drawing)	1
2599-006	Label Ground	1
2599-014	Decal Copper Wire Only	1
2599-038	Label Radio 9310 (not shown on drawing)	1
2599-096	Label Push to Operate	1
2599-100	Sign Warning Gate (not shown on drawing)	2
2599-220	Label Caution Remove Rod (not shown on drawing)	1
2600-238	Capacitor Mounting Clamp 35mm	1
2600-401	Switch Slide Volt Select	1
2600-402	Switch Rocker ON/OFF SnapIn SP	1
2600-408	Switch Rocker ON/OFF SnapIn DP	1
2600-410	Marker Strip Silkscn Both Side	1
2600-413	Terminal Block 3 Position	1
2600-414	Terminal Block 2 Position	1
2600-439	Washer Brass Ground	1
2600-528	Switches and Alarm Box	1
2600-597	Pulley-13" Cast Iron AK130x7/8	1
2600-619	Wire Clip 5/8" Concord 770-1209 (not shown on drawing)	3
2600-719	Gearbox Swing Gate 6500 Spline	1
2600-731	Gasket Switch Cover	1
2600-805	Bushing 1 3/32 Poke Thru Flaps	2
2600-810	Bushing 7/8 Poke Thru Flaps	9
2601-094	Wire Tie 16" x .3 Black (not shown on drawing)	4
2601-197	Motor DC 4" Dia.	1
2601-297	Terminal 187 Qk Dis Full Insul (not shown on drawing)	2
2601-348	Spacer Cover Left Model 9000	2
2601-355	Spacer Nylon 5/8"L x 3/8"ID	3
2615-053	Bolt Hex 3-8-16X1 1-4	2
2615-055	Bolt Hex Head 3/8-16x1.5	4
2615-082	Bolt Hex Head 1/2-13x2	4
2615-153	Bolt Hex Head 5/16-18 x 3/4	3
2615-430	Bolt Flat Hd Hex 3/8-16x3/4 SS	4
2615-655	Bolt Carriage SS 5/16-18 x 2.5	1
2616-000	Screw Phillips Head 6-32 x 1/4 (not shown on drawing)	2
2616-001	Screw Phillips Head 6-32 x 3/8	8
2616-002	Screw Phillips Head 6-32x1/2	2
2616-003	Screw Phillips Head 6-32x3/4SS	2
2616-007	Screw Phillips Head 6-32 x 5/8 (not shown on drawing)	2
2616-018	Screw Phillips Head 8-32x1/2 (not shown on drawing)	6
2616-019	Screw Phillips Head 8-32x3/4	4
2616-051	Screw Phillips 10-32x3/8	2
2616-062	Screw Phillips Head 10-32 x 3.0 Zinc	2
2616-097	Set Screw 5/16-18x3/8 (not shown on drawing)	2
2620-019	Washer 3-8 ID SAE	4
2620-028	Washer 5/16" USS	5
2620-047	Lockwasher 3/8-16	6
2620-050	Lockwasher 1/2"	4
2620-076	Washer 1.125IDx1.63ODx.125T	2
2620-405	Nut 3/8-16	4
2620-409	Nut Hex Flange Lock 1/4-20	2
2620-411	Nut Hex Flange Lock 5/16-18	13
2620-420	Nut Hex 1/2-13	4
2620-494	Nut Jamb 3/4-16	2
2630-007	Snap Ring 1.125" ID	1
2700-104	Box 23.25" x 19" x 34" (not shown on drawing)	1
2700-119	Box 11.125" x 9" x 2.5" (not shown on drawing)	1
2700-401	Pallet 23" x 18.75" x 14" (not shown on drawing)	1

2900-905	Standoff Aluminum 7/16" 6-32 (not shown on drawing)	1
2902-003	Nut Nylon Locking 6-32	3
2902-004	Nut Nylon Lock 8-32 (not shown on drawing)	4
2902-006	Nut Nylon Locking 10-32	2
2902-007	Nut Keps 5/16-18 Lock	3
2902-010	Nut Nylon Locking 8-32	1
3129-002	Terminal Block Cover 2 Position	1
3500-023	Capacitor 4700uf 63V Screw ter	1
4001-020	Terminal 20 Pin	1
4001-021	Key Polarizing Tyco 1437410-5 (not shown on drawing)	1
4001-055	Lock Cabinet 10025 180deg 16001	1
4001-089	Transformer 300VA Tor 115/230-24V	1
4001-109	Mov Assembly 275VAC Varistor	1
4100-018	PCB Gate Operator	1
4601-053	Fuse Assembly (not shown on drawing)	1
6500-025	Bolt Center Tapped	2
6500-047	Belt 47in for 17in Pulley 4L470	1
6500-106	Switch Box Bracket	1
6500-118	Shaft Support Assembly	1
6500-121	Capacitor Plate	1
6500-152	Base Stand Swinger 6500	1
6500-200	Tool-Hub Clutch Release	1
6500-307	Cover Lock Panel	1
6500-313	Battery Tray DC	1
6500-400	Hub Assembly 1/2HP	1
6500-430	Arm Main Assembly (not shown on drawing)	1
6500-440	Cover Turet Assembly	1
6500-454	Cover Front Slip and Lock	1
6500-464	Cover Back with Labels	1
6524-005	Cover Plastic Screen 6524 AC	1
6524-065	Manual Installation Swing Gate (not shown on drawing)	1
6524-380IPB	Swing Gate Oper DC Primary IPB	1
6600-035	Limit Switch Single Sensor	2
7082-186	Wire Set 6524 Swing (not shown on drawing)	1
9024-136	Wire RS485 Cable 15m (50ft) (not shown on drawing)	1
9024-197	Resistor Assembly Bleeder (not shown on drawing)	1
9350-100	Enclosure Model 9000	1
9402-053	Tubing Flex/slit 1/4" OD - 2inch (not shown on drawing)	1
9402-055	Tubing Flex Split 1/2" OD - 0.2FT (not shown on drawing)	1
PartNo	Description	Qty

DRAWN	Tpham		DWG. NO.	6524-380	REV.	D
DATE	11/02/20		NAME	Swing Gate Operator DC Primary	WHERE USED	
PROPRIETARY & CONFIDENTIAL: The information contained in this drawing is the sole property of DoorKing, Inc. Any reproduction in part or as a whole without written permission of DoorKing, Inc. is prohibited.						
DO NOT SCALE TO DRAWING			SHEET SIZE	A	SCALE: 1:50	SHEET 4 OF 4