

MODEL 8040 MicroPlus® / MicroClik® RF RECEIVER

DoorKing Part Numbers

8040-080

318 MHz
Use with MicroPLUS or MicroCLIK Transmitters

8040-081

418 MHz
Use with MicroCLIK 418 MHz Transmitters ONLY

The model 8040 receiver is a versatile RF receiver that can output received transmitter codes in 26, 30 or 31-bit wiegand format allowing it to be used with most access controllers, or it can be used as a stand-alone receiver using its built-in Form C (NO, NC, C) dry contact relay. A "Master" transmitter can be setup and used to quickly put the RF receiver into "Learn Mode" to program additional transmitter codes.

The 8040-080 receiver operates at 318 MHz and can be used with both MicroPlus® and MicroClik® transmitters set to this frequency. The 8040-081 receiver operates at 418 MHz and can ONLY be used with MicroClik® transmitters set to this frequency.

MicroPlus® Transmitters

Over 286,000,000 transmitter codes available plus an encrypted sync code (often called a "rolling code") that changes every time the transmitter is used. Available in 1 – 2 – 3 – 4 button versions, 318 MHz only. MicroPlus® transmitter codes cannot be copied assuring that only the original intended transmitters will activate the access control system.

As such, MicroPlus® transmitters are not compatible with the HomeLink® system found in many automobiles.



MicroPlus® Transmitters

MicroClik® Transmitters

Over 1,000,000 transmitter codes available. Available in 1 – 2 – 3 button versions, 318 or 418 MHz. MicroClik® transmitters are compatible with the HomeLink® system found in many automobiles.



MicroClik® Transmitters

Installation

This receiver is **NOT** designed to be installed outdoors without being protected from the weather. An outdoor enclosure is available for the receiver if required, (P/N 8057-110 - Metal Outdoor Box).

Install the 8040 receiver in a location so the antenna is **NOT surrounded by metal and is in free air as high as possible above the ground**. A longer Coax Antenna kit is available for the receiver if required (P/N 1514-073 - Includes antenna, mounting "L" bracket and 15 feet of coax cable). An antenna amplifier kit (P/N 8052-080) or a Yagi directional antenna kit (P/N 1514-072 -318 MHz ONLY) is also available for the receiver if greater range is required.

The **Program LED** on the side of the case will blink as RF energy is received. If the program LED blinks or is on continuously, this indicates that there may be interference on the frequency (318 MHz) and short range may be the result. If this happens, try relocating the receiver or remove the source of interference.

An antenna amplifier or a directional antenna may be needed.

Power

Separate Power Source:

(Provides greater range.)
Connect 12 - 24 Volt AC or DC power to terminals #1 and #2.
Use minimum 18 AWG wire to power the receiver.

- If DC power is used (Transformer): Terminal #1 is **NEGATIVE** and terminal #2 is **POSITIVE**.
- Power can be supplied to the receiver by the wiegand access controller instead of a separate power source.

⚠ DC Polarity Matters!

- To Receiver Terminal #1 (Neg.)
- To Receiver Terminal #2 (Pos.)

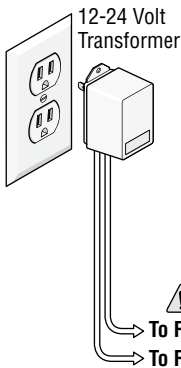

Wiegand Access Controller Connection

Removable receiver terminal for easy wiring.

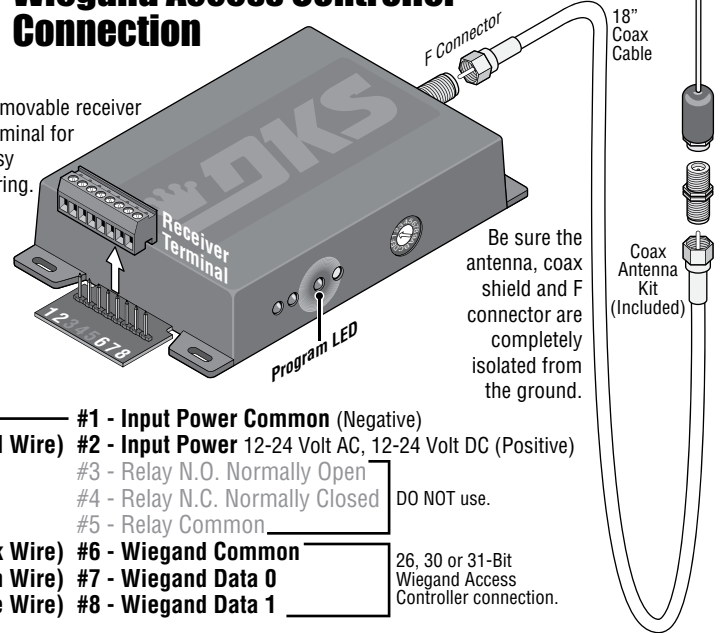

Be sure the antenna, coax shield and F connector are completely isolated from the ground.

- Jumper. See note.
- | | |
|---|--|
| #1 - Input Power Common (Negative) | |
| (Red Wire) #2 - Input Power 12-24 Volt AC, 12-24 Volt DC (Positive) | |
| #3 - Relay N.O. Normally Open | DO NOT use. |
| #4 - Relay N.C. Normally Closed | |
| #5 - Relay Common | |
| (Black Wire) #6 - Wiegand Common | 26, 30 or 31-Bit Wiegand Access Controller connection. |
| (Green Wire) #7 - Wiegand Data 0 | |
| (White Wire) #8 - Wiegand Data 1 | |

Wiegand Access Controller Wiring:

Receiver terminal #2 is **INPUT POWER** (12-24 V).
Receiver terminal #6 is wiegand input power **COMMON**.
Receiver terminal #7 is wiegand **DATA 0**.
Receiver terminal #8 is wiegand **DATA 1**.

NOTE: Terminals #1 and #6 **MUST** be wired together if **NOT** using a separate power source.

Use 22 AWG **shielded** wire, maximum **200 feet**, for wiegand access controller wiring. Connect these terminals to the corresponding terminals on the wiegand access controller. Refer a DoorKing wiegand access controller installation manual for specific wiring information.

How Receiver Functions

The 8040 receiver responds to the MicroPlus or MicroClik transmitter's "Transmitter Code" that is defined by "Transmitter Button Codes" and "Facility Codes". For example: an 8040 receiver can be programmed to respond to only the first button on a multiple button MicroPlus or MicroClik transmitter while a second 8040 receiver can be programmed to respond to only the second button of the same multiple button MicroPlus or MicroClik transmitter. Thus allowing a single multiple button MicroPlus or MicroClik transmitter to activate **two different receivers** without fear of both receivers responding to the same transmitter code. In wiegand output mode (Program selector setting 2, 3 or 4), you have the option of having the receiver **match** (Program selector setting 5) or **ignore** (Program selector setting 6) the facility code to allow the receiver to activate. One receiver can be programmed to respond to a specific facility code while another receiver can be programmed for a different facility code.

Master transmitters can be created to quickly program in new transmitters.

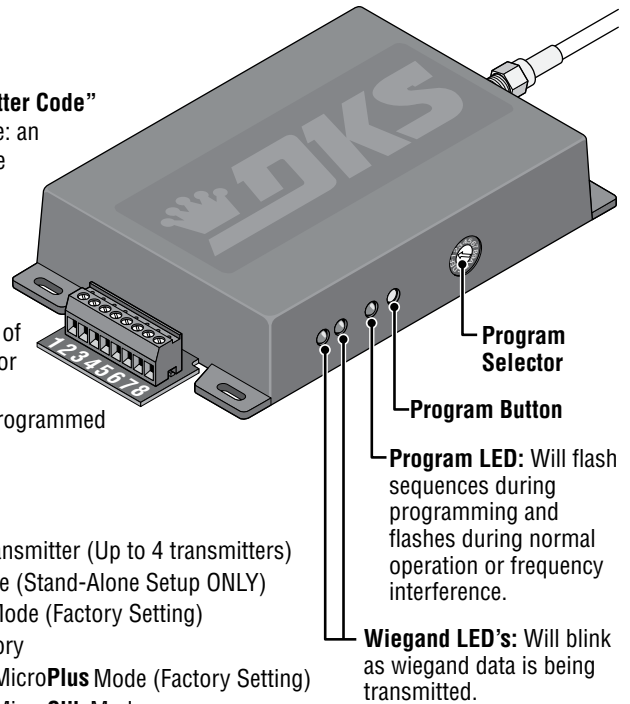

Programming Selector's 11 positions:

1. Learn Single Transmitter
2. 26-bit Wiegand Mode (Factory Setting)
3. 31-bit Wiegand Mode
4. 30-bit Wiegand Mode
5. Match Facility Code
6. Ignore Facility Code (Factory Setting)
7. Learn Master Transmitter (Up to 4 transmitters)
8. Low-Power Mode (Stand-Alone Setup ONLY)
9. Normal-Power Mode (Factory Setting)
- A. Erase ALL Memory
- B. Set Receiver to MicroPlus Mode (Factory Setting)
- C. Set Receiver to MicroClik Mode
- D-F. Not Used

Program LED: Will flash sequences during programming and flashes during normal operation or frequency interference.

Wiegand LED's: Will blink as wiegand data is being transmitted.

Check if Receiver is set for MicroPlus® or MicroClik® Mode

1. Turn receiver's power OFF then back ON.
2. Receiver will BEEP **twice** for MicroClik mode. Receiver will BEEP **three times** for MicroPlus mode (Factory Setting).

If you need to change the receiver's mode, follow the steps below.

CAUTION: Changing an **EXISTING** programmed receiver from one mode to the other will erase **ALL EXISTING MEMORY** that has been previously programmed in the receiver. This cannot be **UNDONE**.

Change Mode (MicroPlus or MicroClik)

- 1A. Turn the Programming Selector to "**Position B**" will change to MicroPlus mode.
- 1B. Turn the Programming Selector to "**Position C**" will change to MicroClik mode.
2. Press and hold Program Button until the Program LED flashes ONCE and receiver will BEEP once. Press and hold button again, LED will flash and receiver will beep. Press and hold button a third time until LED continually flashes and beeps.
Note: If receiver does not emit a continuous beep after pressing the button 3 times, try repeating step 2 faster or slower until it does.
3. Turn power OFF, then back ON. Receiver will BEEP twice for MicroClik mode (1B) or three times for MicroPlus mode (1A).

Learn a Single Transmitter for Wiegand Output

Only a single transmitter needs to be programmed (Learned) into the receiver memory. All other transmitters that match the **Learned** transmitter's **Facility Code** and **Transmitter Button Code** will be output in wiegand format to the access controller.

Important: This programming is for wiegand output to an access controller **ONLY** and will **NOT** work when using the Stand-Alone setup (Relay connection). Low power mode can only be used in Stand-Alone setup.

1. Turn the Programming Selector to **Position 1**.
2. Press and **HOLD** Program Button until the Program LED flashes ONCE and receiver will BEEP once. Receiver is now in "**Learn Mode**" and will flash and beep for 10 seconds.
3. Press a **specific** button on the desired transmitter to be "**Learned**" within 10 seconds, wait for the receiver to time-out. All desired transmitters with matching facility/button codes will now operate when their button is pressed.

26, 30 or 31-Bit Wiegand Output

The receiver can be changed from the factory set 26-Bit to 30 or 31-Bit wiegand output if desired.

- 1A. Turn the Programming Selector to “**Position 2**” will change to **26-Bit Wiegand** (Factory Setting).
- 1B. Turn the Programming Selector to “**Position 3**” will change to **31-Bit Wiegand**.
- 1C. Turn the Programming Selector to “**Position 4**” will change to **30-Bit Wiegand**.
2. Press and hold Program Button until the Program LED flashes ONCE and receiver will BEEP once.
3. Receiver LED will then give a long flash and beep.
4. This indicates receiver is now changed to “**Your Selected Wiegand Bit Size Chosen in Step 1**”.

Match or Ignore Facility Code

The receiver can be programmed to MATCH or IGNORE the Learned transmitter’s facility code.

Important: If using **8096 MicroPlus**® 4-button transmitters, the facility code **MUST** be set to **MATCH**, “**STEP 1A**”.

- 1A. Turn the Programming Selector to “**Position 5**” will **MATCH** the Learned transmitter’s facility code.
- 1B. Turn the Programming Selector to “**Position 6**” will **IGNORE** the Learned transmitter’s facility code (Factory Setting).
2. Press and hold Program Button until the Program LED flashes ONCE and receiver will BEEP once.
3. Receiver LED will then give a long flash and beep.
4. This indicates receiver is now changed to “**Your Selection in Step 1**”.

Learn Master Transmitters (Up to 4 Transmitters)

Up to 4 **Master** transmitters can be created to quickly program new transmitters in the future.

After programming is complete for a master transmitter’s button, when that desired button is pressed, it puts the receiver into “**Learn Mode**” for that button. New transmitters can then be programmed in. Press each **NEW** transmitter’s desired button within a 10 sec. time period to have receiver learn new transmitters. Wait for receiver to time out (10 sec) when finished.

1. Turn the Programming Selector to “**Position 7**”.
2. Press and hold Program Button until the Program LED flashes ONCE and receiver will BEEP once. Receiver is now in “Learn Mode” and will flash and beep every second for 10 seconds.
3. Press the button on the master transmitter to be “Learned” within 10 seconds. Receiver will reset 10 second timer after each master transmitter button has been pressed.
4. Press other master transmitter buttons to be learned, each within a 10 second time period.
5. After all desired master transmitters have been learned by the receiver (up to 4 total), wait for the receiver to time-out.

Note: Keep master transmitters is a secure place.

NORMAL -Power Mode (Factory Set)

The receiver comes from the factory already set in NORMAL-Power mode. It can be changed from LOW-Power back to NORMAL-Power mode.

1. Turn the Programming Selector to **Position 9**.
2. Press and hold Program Button until the Program LED flashes ONCE and receiver will BEEP once.
3. Receiver LED will then give a long flash and beep.
4. This indicates receiver will be put into NORMAL-Power mode which consumes **MORE** power than LOW-Power mode.

Change to LOW -Power Mode

The receiver can be changed from normal-power to LOW-Power mode. LOW-power mode is used in DoorKing solar gate operator applications. Wiegand output will **NOT** work in LOW-Power mode.

1. Turn the Programming Selector to **Position 8**.
2. Press and hold Program Button until the Program LED flashes ONCE and receiver will BEEP once.
3. Receiver LED will then give a long flash and beep.
4. This indicates receiver will be put into LOW-Power mode which consumes **LESS** power than NORMAL-Power mode.

Erase ALL Memory - This CANNOT be UNDONE

1. Turn the Programming Selector to **Position A**.
2. Press and hold Program Button until the Program LED flashes ONCE and receiver will BEEP once. Press and hold button again, LED will flash and receiver will beep again. Press and hold button a third time, LED will flash and receiver will beep a third time.
3. The receiver will then emit a long flash and long beep indicating ALL memory, including master transmitters have been erased from memory.

Note: If receiver does not emit a continuous beep after pressing the button 3 times, try repeating step 2 faster or slower until it does.

STAND-ALONE RECEIVER SETUP - RELAY CONNECTION

The receiver contains a built-in relay that can operate an access device such as a gate operator or door lock. Connect receiver terminals #3 and #5 to a normally open access device or terminals #4 and #5 to a normally closed access device. **The memory of the receiver can ONLY store 100 MicroPLUS or MicroCLIK transmitters MAXIMUM.** The relay will activate when the correct **Facility Code** and **Transmitter Button Code** match the codes that have been stored in the memory from a single transmitter (Learned).

Access Device Relay Connection

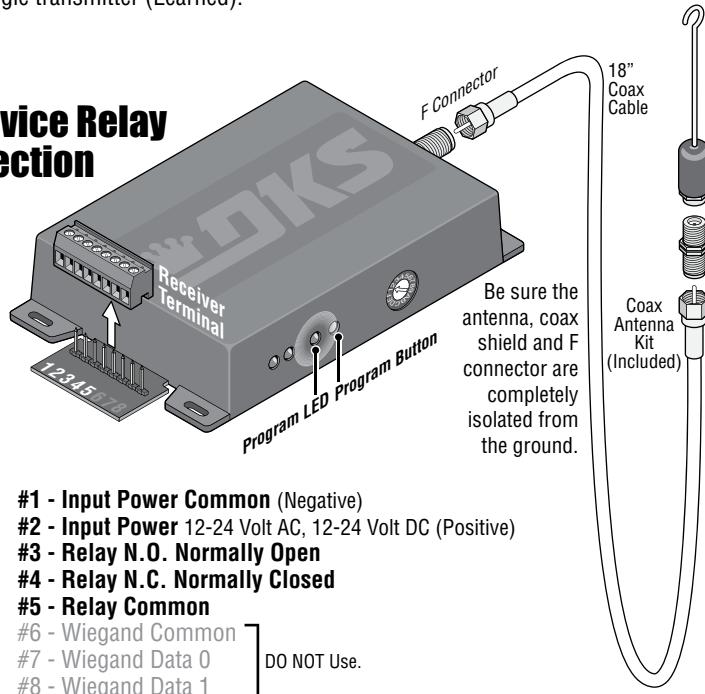

Programming Selector's 8 positions that can be used:

1. Learn Transmitters (See below)
5. Match Facility Code
6. Ignore Facility Code (Factory Setting)
8. Low-Power Mode (Stand-Alone Setup ONLY)
9. Normal-Power Mode (Factory Setting)
- A. Erase ALL Memory
- B. Set Receiver to MicroPlus Mode (Factory Setting)
- C. Set Receiver to MicroClik Mode

Learn Up to 100 Transmitters

1. Turn the Programming Selector to **Position 1**.
2. Press and **HOLD** Program Button until the Program LED flashes ONCE and receiver will BEEP once. Receiver is now in "**Learn Mode**" and will flash and beep every second for 10 seconds.
3. Press a **specific** button on the desired transmitter to be "**Learned**" within 10 seconds. Receiver will reset 10 second timer after each transmitter button has been pressed.
4. Press other desired transmitter buttons to be learned, each within 10 seconds.
5. After all desired transmitters have been learned by the receiver, wait 10 seconds for the receiver to time-out and end programming.

