

Entry System Connection Options and Cloud Programming– Your Choice

DoorKing entry system connection options now include the DoorKing Cloud as an added benefit at no additional cost. Using the DoorKing Cloud, you can program and manage your access system from any device (laptop, tablet, smartphone) with an internet connection – a dedicated PC is no longer needed. The DoorKing Cloud is included with Cellular, VoIP, DoIP and IM Server subscriptions.

For more information, please visit:

<https://www.doorking.com/cloud>

A word about Plain Old Telephone Service (POTS)

The telecommunication infrastructure is changing to digital and fiber networks, some of which do not support modem communications. For these reasons, DoorKing does not recommend using POTS lines for your entry system programming or voice communication requirements.

Programming your DKS telephone entry / access control system using legacy modem-to-modem connections (a modem and phone line at your PC) is becoming difficult to maintain. Modems are essentially obsolete and their performance is affected by the type of telephone service at your PC. There are also many variable factors that can affect the modem, including the brand and model of the programming PC, which OS version is in use, is the modem connected directly to the PC or through a USB Hub, brand and chipset versions of the modem and modem driver updates. Existing modem-to-modem connections may become unreliable as telephone providers update their systems and infrastructure and as your PC performs updates. These factors are beyond the control of DoorKing.

As of January 1, 2017 DoorKing will no longer offer technical support for communication failures between a PC modem and the DKS entry system modem. If the modem connection is found to be functional at the DKS entry system and DoorKing tech support personnel can connect to it via the DKS IM Server connection service, then this will be the recommended corrective action. Alternately, troubleshooting the PC modem will be the responsibility of the owner and their IT (Information Technology) personnel.

Because of these reasons, DoorKing offers a variety of connection options for our telephone entry and access control systems. **You DO NOT have to subscribe to any DoorKing connection services for your entry system to be serviceable.** The connection options in this price schedule offer easy plug & play connection methods. Other (non-subscription) methods of connection are available but these may require additional hardware, subscriptions to other service providers or internet services and IT personnel for setup requirements (setting up routers, firewalls, port forwarding, DDNS (Dynamic Domain Name System) charges or static IP addresses). In many cases, you will find that the DoorKing options are less costly than legacy options such as a POTS (Plain Old Telephone Service) business line or VoIP (Voice over Internet Protocol) service providers.

Be sure to visit the DoorKing web site for complete terms and conditions of using DoorKing connection service products.

Table of Contents

Connection Options

DKS Cellular	4
DKS Internet	6
DKS IM Server	8

Cellular Connection

Wireless

DKS Cellular

- Plug & Play
- No phone lines or internet cables to run
- No obsolete slow modems
- Crystal clear sound – no hums or buzzes
- Practically immune to power surges / lightning
- Connect up to two (2) systems
- Includes power transformer
- Competitive monthly rates

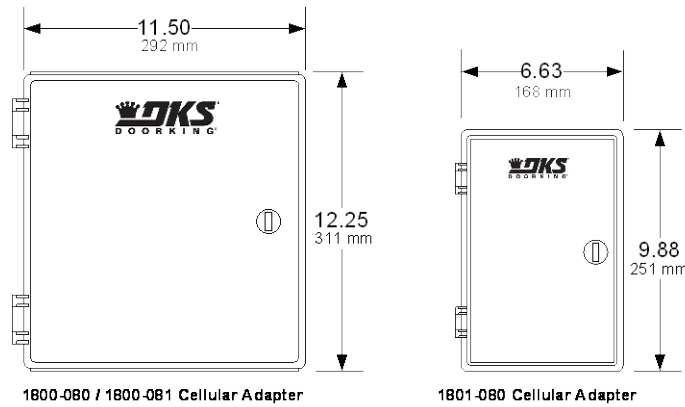

Model	Service ¹	Voice ²	Data ³	Use With
1800-080	DKS Cellular	Yes	Yes	1833, 1834, 1835, 1837, 1838
1800-081	DKS Cellular	Yes	Yes	1802 AP, 1808 AP, 1810 AP, 1812 AP, 1838 AP
1801-080	DKS Cellular	Yes	No	1802, 1802-EPD, 1803, 1808, 1810, 1812, 1819

1. DKS Cellular is provided by AT&T 4G-LTE where available.
2. Voice only cellular service will not support modem communications.
3. Data means the ability to program the entry system from your PC with the DoorKing software application.

Cellular Connection

Wireless

DKS Cellular

DKS Cellular is a wireless option that replaces standard telephone lines and internet connections and offers voice communication and/or data (programming) to the DKS telephone entry / access control system via the AT&T 4G LTE cellular network (where available). DKS Cellular is available in all states including Alaska and Hawaii and is also available in Puerto Rico, all U.S. territories, Canada and Mexico. This is a monthly cellular subscription service without any long term contracts. DKS Cellular plans include all taxes, fees and charges for voice and data communication, including long distance charges.

Billing is based on a combination of voice minutes and/or number of data transfers during the monthly billing period. A data transfer is defined as: receiving data; sending data; receiving transactions. Exceeding either voice minutes or data transfers at one billing level will move you into the next billing level for that billing period. As such, you may see different billing amounts on a month to month basis. Please note that if you terminate the service, you will receive a final billing on your normal billing date for services used prior to the termination.

There is a one-time activation fee of \$45.00 for each cellular control box registered. There is a \$2.00 / month discount offered on all cellular plans if auto-pay (via credit card or e-check) is selected.

See Section A 2.0, page 36 for cellular control box prices.

Voice + Data Plans			
Voice Minutes / Month	Data Transfers / Month	Monthly Fee	Applies to:
Up to 100	Up to 6	41.95	1800-080, 1800-081
101 – 450	7 – 60	51.95	
451 – 1200	61 – 90	61.95	
1201 – 2500	91 – 120	71.95	
2501 +	121 +	77.95	
Voice Only Plans			
Voice Minutes / Month	Data Transfers / Month	Monthly Fee	Applies to:
Up to 100		36.95	1801-080
101 – 450		43.95	
451 – 1200		51.95	
1201 – 2500		59.95	
2501 +		66.95	
Data Only Plans			
Voice Minutes / Month	Data Transfers / Month	Monthly Fee	Applies to:
	Up to 60	30.95	1800-080, 1800-081 (Use data only plans with 1838-081 and 1838-095 products)
	61 - 120	40.95	
	121 +	50.95	

Internet Connection

Wired (Ethernet)

DKS Internet

- VoIP + Data connection
- VoIP or Data only options
- Plug & Play
- Easy installation and setup

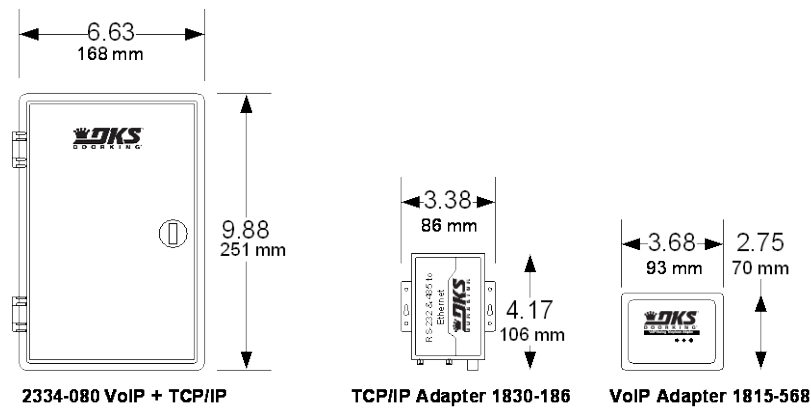

Model	Service ¹	Voice	Data ²	Note ³
2334-080	DKS Internet	Yes	Yes	Provides voice + data connection for 1833, 1834, 1835, 1837, 1838
1830-186	DKS Internet	No	Yes	Provides data connection only for 1833, 1834, 1835, 1837, 1838
1815-568	DKS Internet	Yes	No	Provides VoIP. No data (programming) with this. Can be used to replace POTS lines on most telephone entry systems that do not require remote programming.

1. DKS Internet will not support modem communications.
2. Data means the ability to program the entry system from your PC with the DoorKing software application.
3. The 1830-186 and 1815-568 can be used separately to provide both voice (VoIP) and data (programming) features. However, this would require two (2) separate Ethernet wire runs from your router (one to each device).

Internet Connection

Wired (Ethernet)

DKS Internet

DKS Internet allows you to replace POTS (Plain Old Telephone Service) lines with your internet connection and offers voice (VoIP) communication and/or data (programming) to the DKS telephone entry / access control system.

DKS Internet requires a network (Ethernet) connection from your router to the DoorKing connection device (2334-080, 1830-186, 1815-568). You should note that distance limitations on network wiring do apply. Ethernet wire runs are limited to 330 feet (100 m) maximum.

This is a flat rate monthly or yearly subscription service without any long term contracts and includes all taxes, fees and charges for voice and/or data communication. There is a 5% per month discount offered if auto-pay (via credit card or e-check) is selected.

See Section A 2.0, page 36 for connection device prices.

DKS Internet			
Plan	Pay per Month	Pay per Year	Notes
VoIP + Data	25.95	285.45	Use this plan if you are using the 2334-080. Provides both voice communication and programming of the DKS entry system. This option is best for 1833, 1834, 1835 and 1837 systems.
VoIP Only	21.95	241.45	Use this plan if you are using the 1815-568 for voice communication only. Programming the entry system would have to be by another method. This option is best for 1802, 1803, 1808, 1810, 1812 and 1819 systems.
Data Only	6.95	76.45	Use this plan if you are using the 1830-186 for programming only. Voice communication would have to be by another method. This option is best for the 1838 system.

Telephone Line Connection

Wired (POTS)

DKS IM Server Modem^{Pat: 9,049,306}

- Plug & Play data transfer (programming)
- Voice communication provided by local phone company
- Uses your computers internet connection
- Uses the POTS (Plain Old Telephone Service) line at the entry system

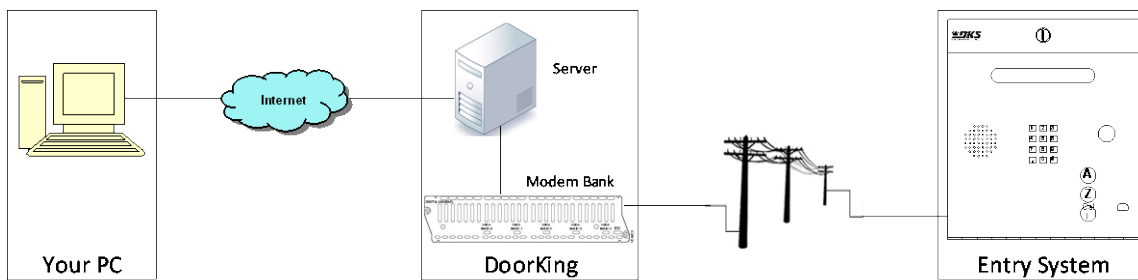

1. No connection hardware to purchase or install.
2. Uses the internet connection at your PC to send programming data to the DoorKing server.
3. The DoorKing server transfers the data to an open modem in our modem banks.
4. The modem uses plain old telephone service (POTS) to place a call to the entry system.
5. When the handshake between the modem and the entry system is verified, data is transferred via modem communication.
6. Acknowledgement upon programming completion is sent back to your PC.

Telephone Line Connection

Wired (POTS)

DKS IM Server Modem¹

DKS IM Server utilizes the POTS (Plain Old Telephone Service) line connected to the entry system to transfer (send) programming data to the DKS telephone entry / access control system via the internet connection at your programming computer. Voice communication is provided over the POTS line². This service is useful if your programming PC does not have a modem, or if your modem cannot communicate with the entry system modem. This is a monthly subscription service without any long term contracts and includes taxes and charges for the data communication only³. DKS IM Server Modem is only available for use with 1830 series and Access Plus series systems.

You should also be aware that many telecommunication companies no longer support or install POTS lines. Additionally, the telecommunication infrastructure is changing to digital and fiber networks, some of which do not support modem communications. For these reasons, DoorKing does not recommend using POTS lines for your entry system programming or voice communication requirements. The preferred connection method for your entry system should be via a cellular or internet connection.

Billing is based on the number of tenants/residents in the entry system database. You should also be aware that DoorKing maintains the right to determine excessive usage (data transfers) at any time and may require you to reduce your usage (data transfers). Failure to comply may result in service termination.

1. The IM Server Modem (Pat: 9,049,306) is maintained only as a convenience for legacy customers still using a POTS line as their voice/data connection method. DoorKing does not recommend using a POTS line for your voice/data connection. We can no longer guarantee modem connections as some phone company services and switches no longer support modem communications since these devices are considered to be obsolete technology.
2. The telephone line at the entry system must support G.711 level service for the IM Server Modem to work. You should also be aware that modem communications will not work over cellular or VoIP connections.
3. The user is responsible for all phone company charges including local and long distance charges, taxes and other fees associated with the POTS line connected to the entry system.

DKS IM Server		
Residents/Tenants	Pay per Month	Pay per Year
0 - 100	9.95	109.45
101 - 250	12.45	136.95
251 - 500	14.95	164.45
501 +	18.45	202.95

A Word about POTS

Programming your DKS telephone entry / access control system using legacy modem-to-modem connections (a modem and phone line at your PC or DoorKing modem banks) is becoming difficult to maintain. Modems are essentially obsolete and their performance is affected by the type of telephone service at your PC. There are also many variable factors that can affect the modem, including the brand and model of the programming PC, which OS version is in use, is the modem connected directly to the PC or through a USB Hub, brand and chipset versions of the modem and modem driver updates. Existing modem-to-modem connections may become unreliable as telephone providers update their systems and infrastructure and as your PC performs updates. These factors are beyond the control of DoorKing and for these reasons, we do not recommend using a POTS line for your entry system voice/data connection.

As of January 1, 2017 DoorKing no longer offers technical support for communication failures between a PC modem and the DKS entry system modem. If the modem connection is found to be functional at the DKS entry system and DoorKing tech support personnel can connect to it via the DKS IM Server connection service, then this will be the recommended corrective action. Alternately, troubleshooting the PC modem will be the responsibility of the owner and their IT (Information Technology) personnel.

