



9500 SERIES

MAXIMUM SECURITY VEHICULAR GATE OPERATORS



large gates
up to 20,000 Lbs



direct drive
limit switches



solid-state
variable speed control



no slip chain drive
#100 roller chain

- User adjustable variable speed control: 1-4 ft/sec
- Slow-start / slow-stop operation
- High tensile strength #100 roller chain provides a direct mechanical linkage to the gate, will not slip and is unaffected by weather or other contaminants such as dirt, oil, grease, ice, etc.
- Integral internal direct driven limit switch system cannot be tampered with externally
- Anti-tailgating and partial open features to help control unauthorized vehicle access
- Ports for plug-in loop detectors
- 115 VAC convenience outlets
- Built-in power switch and 3-button control station

FEATURES

ACCESS CONTROL SOLUTIONS





VEHICULAR GATE OPERATORS

The DKS 9500 Series of vehicular slide gate operators are designed for use on very large and very heavy gates in maximum security applications only. Rather than rely on a friction drive rail system that can be difficult to install, often slip in inclement weather or can be easily compromised, DKS maximum security gate operators use a high tensile steel alloy #100 roller chain to provide a direct mechanical connection to the gate. The 9500 Series operators feature a solid-state speed control module that starts and stops the gate slowly. The operating speed of the gate is user adjustable (up to 4-ft/sec) making this operator ideal for security sensitive areas where perimeter security must be maintained.

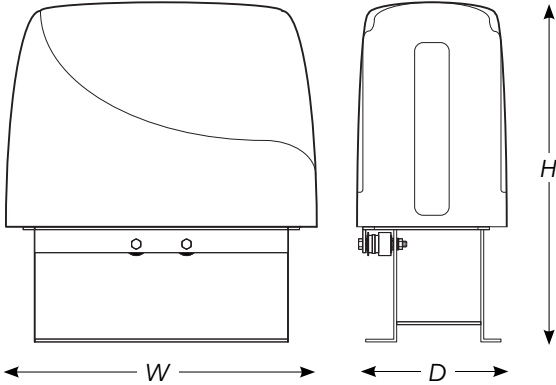

9500 Series
 54" W x 59" H x 26" D
 137.16cm W x 149.86cm H x 66.04cm D

9500 Series Specs

Gate Speed	Max Gate Length *	Max Gate Weight *	HP	Volt/Phase	Amps
1 -2 Ft / Sec	160 Ft	10,000 Lbs.	3HP	230 VAC / 1	17 A
1 -2 Ft / Sec	160 Ft	10,000 Lbs.	3HP	230 VAC / 3	9.2 A
1 -2 Ft / Sec	160 Ft	10,000 Lbs.	3HP	460 VAC / 3	4.6 A
1 -4 Ft / Sec	160 Ft	10,000 Lbs.	5HP	230 VAC / 3	15.4 A
1 -4 Ft / Sec	160 Ft	10,000 Lbs.	5HP	460 VAC / 3	8.2 A
1 -2 Ft / Sec	160 Ft	20,000 Lbs.	5HP	230 VAC / 3	12.4 A
1 -2 Ft / Sec	160 Ft	20,000 Lbs.	5HP	460 VAC / 3	6.2 A

* Assumes gate to be level and in good operating condition.

General Specs

Class of Operation

III (Limited), IV (Restricted)

Mechanical

3/8" Steel frame

1/4" polyethylene molded cover rated NEMA 4x

Primary reduction: Heavy-duty gear reducer running in a continuous oil bath.

Standard speed operators use a 40:1 Reduction

High speed operators use a 10:1 Reduction

Chain: #100 Roller chain

Speed: Standard operators 1-2 Ft/Sec
 High speed operators 1-4 Ft/Sec

Brake: Spring-set, electrically released, self adjusting disc brake with manual release (used on high speed operators only)

Operator kit

Includes chain brackets, hardware and 20' of #100 chain

Advanced Features

Adjustable speed control circuit:

Standard speed operators: 1-2 ft/sec

High speed operators: 1-4 ft/sec

Slow start / slow stop

Adjustable partial open

Anti-tailgating

Selectable stop / reverse loop function

Direct driven limit switches

Built-in power switch

Built-in 3-button control (open-close-stop)

Warn-before-operate function

Built-in diagnostics check for specific fault conditions

Port for plug-in loop detectors (DKS Detectors only)

Two 115 VAC Convenience outlets

Note

This vehicular slide gate operator is designed for Class III and IV applications only and should never be used in applications serving the general public such as apartment complexes, gated communities, residential applications, parking garages, etc.

Options

Chain tray – recommended on gates exceeding 20-ft in length

Gate Tracker reporting provides operator data to a companion DKS access control system (models 1833, 1835, 1837 and 1838)

Red/Green traffic signal provides a visual indication when the gate is safe & it is OK for traffic to proceed

Non-contact (photocells) and contact (sensing edges) secondary entrapment prevention devices

Operating Temp

10°F to 140°F -12°C to 62°C

Optional heater kit recommended for colder environments

Shipping Weight

Approximately 700 to 875 Lbs (317kg to 397kg)

Warranty

5 Years

Distributed by:

DOORKING®, INC.

120 Glasgow Avenue, Inglewood, California 90301 U.S.A. Tel: 310-645-0023 FAX: 310-641-1586 www.doorking.com

© 2009 All Rights Reserved. Product specifications may change without notice. Rev. 7/09

MEMBER:

